

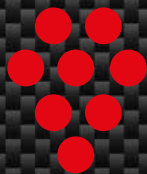

# RIEDEL SUPERLEGGERO



**ON PREMISE**  
**PICTURE BOOK 2023**

EFFECTIVE: MAY 1<sup>ST</sup>, 2023

IF YOUR WINE COULD CHOOSE A GLASS, IT WOULD BE RIEDEL.

RIEDEL SUPERLEGGERO



**NEW ITEMS 2023**

RIEDEL SUPERLEGGERO RESTAURANT ..... 4  
 RIEDEL DRINK SPECIFIC GLASSWARE ..... 7

**ON PREMISE GLASS COLLECTION**

RIEDEL SUPERLEGGERO RESTAURANT ..... 8  
 SOMMELIERS RESTAURANT ..... 10  
 RIEDEL VELOCE RESTAURANT ..... 12  
 RIEDEL WINEWINGS RESTAURANT ..... 14  
 RIEDEL PERFORMANCE RESTAURANT ..... 16  
 RIEDEL VERITAS RESTAURANT ..... 18  
 VINUM RESTAURANT ..... 22  
 RIEDEL EXTREME RESTAURANT ..... 24  
 RIEDEL RESTAURANT ..... 26  
 RIEDEL BAR RESTAURANT ..... 30  
 RIEDEL DRINK SPECIFIC GLASSWARE RESTAURANT ..... 32  
 RIEDEL WINE FRIENDLY RESTAURANT ..... 36  
 OUVERTURE RESTAURANT ..... 38  
 DEGUSTAZIONE ..... 39  
 RIEDEL TUMBLER COLLECTION RESTAURANT ..... 40  
 RIEDEL MANHATTAN ..... 44  
 SL RIEDEL STEMLESS WINGS RESTAURANT ..... 45  
 RIEDEL O RESTAURANT ..... 46  
 SWIRL RESTAURANT ..... 51  
 CALIBRATION MARK ..... 52

**ACCESSORIES ..... 56**

**DECANTERS HANDMADE ..... 58**

**DECANTERS MACHINE-MADE ..... 74**

LOGO AND POUR AID ..... 76  
 INSTRUCTIONS ..... 78  
 TRADEMARK ..... 79  
 CUSTOM MADE ..... 80  
 TASTING EVENTS ..... 82  
 GO GREEN - SUSTAINABILITY ..... 83  
 SENSORY WORKSHOP ..... 84  
 GENERAL TERMS AND CONDITIONS ..... 85

Shipments are subject to our General Terms and Conditions and respective Payment and Delivery Terms. We do not accept other delivery Terms and Conditions and respective Payment and Delivery Terms. Our General Terms and Conditions of Contract and respective Payment and Delivery Terms may be viewed by means of display and notice board in our business offices and can be submitted on request. You are accepting these General Terms and Conditions and respective Payment and Delivery Terms when the contract is concluded.

We regret any errors in our specifications for sizes, colours, volumes or prices. However, claims resulting from such errors cannot be accepted. The packaging shown are example packaging.



Bordeaux Grand Cru



Burgundy Grand Cru



Hermitage / Syrah



Riesling

<b>ITEM</b>	Item no.: 0425/00 fine crystal premium machine-made	Item no.: 0425/16 fine crystal premium machine-made	Item no.: 0425/41 fine crystal premium machine-made	Item no.: 0425/15 fine crystal premium machine-made
	Height/glass: 282 mm Capacity/glass: 953 ccm Design: 2023	Height/glass: 276 mm Capacity/glass: 1022 ccm Design: 2023	Height/glass: 267 mm Capacity/glass: 668 ccm Design: 2023	Height/glass: 252 mm Capacity/glass: 400 ccm Design: 2023
<b>PACKAGING</b>	Pieces/Bill unit: 1	Pieces/Bill unit: 1	Pieces/Bill unit: 1	Pieces/Bill unit: 1
<b>TYPE AND QUANTITY</b>	Bill units/MP: 6	Bill units/MP: 6	Bill units/MP: 6	Bill units/MP: 6
<b>MASTERPACK</b>	Length: 346 mm	Length: 372 mm	Length: 329 mm	Length: 350 mm
<b>DIMENSIONS</b>	Width: 234 mm	Width: 249 mm	Width: 220 mm	Width: 205 mm
	Height: 305 mm	Height: 296 mm	Height: 288 mm	Height: 275 mm
	Weight: 1268 gr	Weight: 1308 gr	Weight: 1113 gr	Weight: 915 gr
<b>EURO PALLET</b>	Bill units/pallet: 360	Bill units/pallet: 324	Bill units/pallet: 396	Bill units/pallet: 432
	Bill units/layer: 60	Bill units/layer: 54	Bill units/layer: 66	Bill units/layer: 72
	Layers/pallet: 6	Layers/pallet: 6	Layers/pallet: 6	Layers/pallet: 6
<b>CONTAINER PALLET</b>	Bill units/pallet: 630	Bill units/pallet: 504	Bill units/pallet: 630	Bill units/pallet: 816
<b>HIGH CUBE</b>	Bill units/layer: 90	Bill units/layer: 72	Bill units/layer: 90	Bill units/layer: 102
	Layers/pallet: 7	Layers/pallet: 7	Layers/pallet: 7	Layers/pallet: 8
<b>EAN</b>				
<b>BILL UNIT</b>	9 006206 325979	9 006206 325962	9 006206 326006	9 006206 325917



Champagne Wine Glass



Sauvignon Blanc



Chardonnay



Spirits

ITEM	Item no.: 0425/28 fine crystal premium machine-made	Item no.: 0425/33 fine crystal premium machine-made	Item no.: 0425/97 fine crystal premium machine-made	Item no.: 0425/10 fine crystal premium machine-made
	Height/glass: 260 mm Capacity/glass: 464 ccm Design: 2023	Height/glass: 261 mm Capacity/glass: 400 ccm Design: 2023	Height/glass: 234 mm Capacity/glass: 660 ccm Design: 2023	Height/glass: 244 mm Capacity/glass: 248 ccm Design: 2023
<b>PACKAGING</b>	Pieces/Bill unit: 1	Pieces/Bill unit: 1	Pieces/Bill unit: 1	Pieces/Bill unit: 1
<b>TYPE AND QUANTITY</b>	Bill units/MP: 6	Bill units/MP: 6	Bill units/MP: 6	Bill units/MP: 6
<b>MASTERPACK</b>	Length: 305 mm	Length: 305 mm	Length: 354 mm	Length: 305 mm
<b>DIMENSIONS</b>	Width: 208 mm	Width: 208 mm	Width: 236 mm	Width: 205 mm
	Height: 280 mm	Height: 280 mm	Height: 257 mm	Height: 268 mm
	Weight: 944 gr	Weight: 962 gr	Weight: 1054 gr	Weight: 840 gr
<b>EURO PALLET</b>	Bill units/pallet: 432	Bill units/pallet: 432	Bill units/pallet: 420	Bill units/pallet: 504
	Bill units/layer: 72	Bill units/layer: 72	Bill units/layer: 60	Bill units/layer: 72
	Layers/pallet: 6	Layers/pallet: 6	Layers/pallet: 7	Layers/pallet: 7
<b>CONTAINER PALLET</b>	Bill units/pallet: 864	Bill units/pallet: 864	Bill units/pallet: 624	Bill units/pallet: 864
<b>HIGH CUBE</b>	Bill units/layer: 108	Bill units/layer: 108	Bill units/layer: 78	Bill units/layer: 108
	Layers/pallet: 8	Layers/pallet: 8	Layers/pallet: 8	Layers/pallet: 8
<b>EAN</b>				
<b>BILL UNIT</b>	9 006206 325955	9 006206 325931	9 006206 325924	9 006206 325948



RIEDEL SUPERLEGGERO



Nick & Nora Glass Large



Sour Glass Optic



Coffee Glass

ITEM	Item no.: fine crystal premium machine-made	0417/08	Item no.: fine crystal premium machine-made	0417/09	Item no.: fine crystal machine-made	0417/10
	Height/glass:	177 mm	Height/glass:	158 mm	Height/glass:	63 mm
	Capacity/glass:	198 ccm	Capacity/glass:	215 ccm	Capacity/glass:	90 ccm
	Design:	2023	Design:	2023	Design:	2023
<b>PACKAGING</b>	Pieces/Bill unit:	1	Pieces/Bill unit:	1	Pieces/Bill unit:	1
<b>TYPE AND QUANTITY</b>	Bill units/MP:	12	Bill units/MP:	12	Bill units/MP:	12
<b>MASTERPACK</b>	Length:	348 mm	Length:	402 mm	Length:	272 mm
<b>DIMENSIONS</b>	Width:	255 mm	Width:	297 mm	Width:	205 mm
	Height:	183 mm	Height:	176 mm	Height:	75 mm
	Weight:	1849 gr	Weight:	2012 gr	Weight:	1628 gr
<b>EURO PALLET</b>	Bill units/pallet:	1080	Bill units/pallet:	720	Bill units/pallet:	336
	Bill units/layer:	108	Bill units/layer:	72	Bill units/layer:	15
	Layers/pallet:	10	Layers/pallet:	10	Layers/pallet:	19
<b>CONTAINER PALLET</b>	Bill units/pallet:	1872	Bill units/pallet:	1440	Bill units/pallet:	336
<b>HIGH CUBE</b>	Bill units/layer:	156	Bill units/layer:	120	Bill units/layer:	21
	Layers/pallet:	12	Layers/pallet:	12	Layers/pallet:	16
<b>EAN BILL UNIT</b>	 9 006206 325849		 9 006206 325900		 9 006206 326105	



Bordeaux Grand Cru



Burgundy Grand Cru



Hermitage / Syrah



Riesling

ITEM	Item no.: 0425/00 fine crystal premium machine-made	Item no.: 0425/16 fine crystal premium machine-made	Item no.: 0425/41 fine crystal premium machine-made	Item no.: 0425/15 fine crystal premium machine-made
	Height/glass: 282 mm Capacity/glass: 953 ccm Design: 2023	Height/glass: 276 mm Capacity/glass: 1022 ccm Design: 2023	Height/glass: 267 mm Capacity/glass: 668 ccm Design: 2023	Height/glass: 252 mm Capacity/glass: 400 ccm Design: 2023
<b>PACKAGING</b>	Pieces/Bill unit: 1	Pieces/Bill unit: 1	Pieces/Bill unit: 1	Pieces/Bill unit: 1
<b>TYPE AND QUANTITY</b>	Bill units/MP: 6	Bill units/MP: 6	Bill units/MP: 6	Bill units/MP: 6
<b>MASTERPACK</b>	Length: 346 mm	Length: 372 mm	Length: 329 mm	Length: 350 mm
<b>DIMENSIONS</b>	Width: 234 mm	Width: 249 mm	Width: 220 mm	Width: 205 mm
	Height: 305 mm	Height: 296 mm	Height: 288 mm	Height: 275 mm
	Weight: 1268 gr	Weight: 1308 gr	Weight: 1113 gr	Weight: 915 gr
<b>EURO PALLET</b>	Bill units/pallet: 360	Bill units/pallet: 324	Bill units/pallet: 396	Bill units/pallet: 432
	Bill units/layer: 60	Bill units/layer: 54	Bill units/layer: 66	Bill units/layer: 72
	Layers/pallet: 6	Layers/pallet: 6	Layers/pallet: 6	Layers/pallet: 6
<b>CONTAINER PALLET</b>	Bill units/pallet: 630	Bill units/pallet: 504	Bill units/pallet: 630	Bill units/pallet: 816
<b>HIGH CUBE</b>	Bill units/layer: 90	Bill units/layer: 72	Bill units/layer: 90	Bill units/layer: 102
	Layers/pallet: 7	Layers/pallet: 7	Layers/pallet: 7	Layers/pallet: 8
<b>EAN</b>				
<b>BILL UNIT</b>	9 006206 325979	9 006206 325962	9 006206 326006	9 006206 325917





Champagne Wine Glass







Sauvignon Blanc



Chardonnay



Spirits



ITEM	Item no.: 0425/28 <b>fine crystal premium machine-made</b>	Item no.: 0425/33 <b>fine crystal premium machine-made</b>	Item no.: 0425/97 <b>fine crystal premium machine-made</b>	Item no.: 0425/10 <b>fine crystal premium machine-made</b>
	Height/glass: 260 mm	Height/glass: 261 mm	Height/glass: 234 mm	Height/glass: 244 mm
	Capacity/glass: 464 ccm	Capacity/glass: 400 ccm	Capacity/glass: 660 ccm	Capacity/glass: 248 ccm
	Design: 2023	Design: 2023	Design: 2023	Design: 2023
<b>PACKAGING</b>	Pieces/Bill unit: 1	Pieces/Bill unit: 1	Pieces/Bill unit: 1	Pieces/Bill unit: 1
<b>TYPE AND QUANTITY</b>	Bill units/MP: 6	Bill units/MP: 6	Bill units/MP: 6	Bill units/MP: 6
<b>MASTERPACK</b>	Length: 305 mm	Length: 305 mm	Length: 354 mm	Length: 305 mm
<b>DIMENSIONS</b>	Width: 208 mm	Width: 208 mm	Width: 236 mm	Width: 205 mm
	Height: 280 mm	Height: 280 mm	Height: 257 mm	Height: 268 mm
	Weight: 944 gr	Weight: 962 gr	Weight: 1054 gr	Weight: 840 gr
<b>EURO PALLET</b>	Bill units/pallet: 432	Bill units/pallet: 432	Bill units/pallet: 420	Bill units/pallet: 504
	Bill units/layer: 72	Bill units/layer: 72	Bill units/layer: 60	Bill units/layer: 72
	Layers/pallet: 6	Layers/pallet: 6	Layers/pallet: 7	Layers/pallet: 7
<b>CONTAINER PALLET</b>	Bill units/pallet: 864	Bill units/pallet: 864	Bill units/pallet: 624	Bill units/pallet: 864
<b>HIGH CUBE</b>	Bill units/layer: 108	Bill units/layer: 108	Bill units/layer: 78	Bill units/layer: 108
	Layers/pallet: 8	Layers/pallet: 8	Layers/pallet: 8	Layers/pallet: 8
<b>EAN BILL UNIT</b>	 9 006206 325955	 9 006206 325931	 9 006206 325924	 9 006206 325948



Bordeaux Grand Cru



Burgundy Grand Cru

<b>ITEM</b>	<b>Item no.:</b> 0300/00 <b>fine crystal machine-made</b>	<b>Item no.:</b> 0300/16 <b>fine crystal machine-made</b>
	Height/glass: 270 mm	Height/glass: 248 mm
	Capacity/glass: 860 ccm	Capacity/glass: 1050 ccm
	Design: 2013	Design: 2013
<b>PACKAGING</b>	Pieces/Bill unit: 1	Pieces/Bill unit: 1
<b>TYPE AND QUANTITY</b>	Bill units/MP: 6	Bill units/MP: 6
<b>MASTERPACK</b>	Length: 337 mm	Length: 367 mm
<b>DIMENSIONS</b>	Width: 227 mm	Width: 247 mm
	Height: 293 mm	Height: 270 mm
	Weight: 1680 gr	Weight: 1740 gr
<b>EURO PALLET</b>	Bill units/pallet: 396	Bill units/pallet: 378
	Bill units/layer: 66	Bill units/layer: 54
	Layers/pallet: 6	Layers/pallet: 7
<b>CONTAINER PALLET</b>	Bill units/pallet: 630	Bill units/pallet: 576
<b>HIGH CUBE</b>	Bill units/layer: 90	Bill units/layer: 72
	Layers/pallet: 7	Layers/pallet: 8
<b>EAN BILL UNIT</b>	 9 006206 521104	 9 006206 521111





Cabernet/Merlot



Pinot Noir/Nebbiolo



Syrah/Shiraz



Champagne Wine Glass

<b>ITEM</b>	<b>Item no.:</b> 0330/0 <b>fine crystal</b> <b>premium machine-made</b> Height/glass: 247 mm Capacity/glass: 829 ccm Design: 2022	<b>Item no.:</b> 0330/07 <b>fine crystal</b> <b>premium machine-made</b> Height/glass: 247 mm Capacity/glass: 763 ccm Design: 2022	<b>Item no.:</b> 0330/41 <b>fine crystal</b> <b>premium machine-made</b> Height/glass: 247 mm Capacity/glass: 720 ccm Design: 2022	<b>Item no.:</b> 0330/28 <b>fine crystal</b> <b>premium machine-made</b> Height/glass: 247 mm Capacity/glass: 327 ccm Design: 2022
<b>PACKAGING</b>	Pieces/Bill unit: 1	Pieces/Bill unit: 1	Pieces/Bill unit: 1	Pieces/Bill unit: 1
<b>TYPE AND QUANTITY</b>	Bill units/MP: 6	Bill units/MP: 6	Bill units/MP: 6	Bill units/MP: 6
<b>MASTERPACK</b>	Length: 330 mm	Length: 357 mm	Length: 320 mm	Length: 275 mm
<b>DIMENSIONS</b>	Width: 225 mm	Width: 240 mm	Width: 215 mm	Width: 185 mm
	Height: 270 mm	Height: 270 mm	Height: 270 mm	Height: 270 mm
	Weight: 1131 gr	Weight: 1241 gr	Weight: 1203 gr	Weight: 900 gr
<b>EURO PALLET</b>	Bill units/pallet: 462	Bill units/pallet: 378	Bill units/pallet: 504	Bill units/pallet: 672
	Bill units/layer: 66	Bill units/layer: 54	Bill units/layer: 72	Bill units/layer: 96
	Layers/pallet: 7	Layers/pallet: 7	Layers/pallet: 7	Layers/pallet: 7
<b>CONTAINER PALLET</b>	Bill units/pallet: 720	Bill units/pallet: 624	Bill units/pallet: 768	Bill units/pallet: 1104
<b>HIGH CUBE</b>	Bill units/layer: 90	Bill units/layer: 78	Bill units/layer: 96	Bill units/layer: 138
	Layers/pallet: 8	Layers/pallet: 8	Layers/pallet: 8	Layers/pallet: 8
<b>EAN</b>				
<b>BILL UNIT</b>	9 006206 324323	9 006206 324293	9 006206 324286	9 006206 324255



Sauvignon Blanc







Riesling



Chardonnay



Rosé

ITEM	Item no.: 0330/33 <b>fine crystal premium machine-made</b>	Item no.: 0330/15 <b>fine crystal premium machine-made</b>	Item no.: 0330/97 <b>fine crystal premium machine-made</b>	Item no.: 0330/55 <b>fine crystal premium machine-made</b>
	Height/glass: 247 mm	Height/glass: 247 mm	Height/glass: 247 mm	Height/glass: 247 mm
	Capacity/glass: 347 ccm	Capacity/glass: 570 ccm	Capacity/glass: 690 ccm	Capacity/glass: 347 ccm
	Design: 2022	Design: 2022	Design: 2022	Design: 2022
<b>PACKAGING</b>	Pieces/Bill unit: 1	Pieces/Bill unit: 1	Pieces/Bill unit: 1	Pieces/Bill unit: 1
<b>TYPE AND QUANTITY</b>	Bill units/MP: 6	Bill units/MP: 6	Bill units/MP: 6	Bill units/MP: 6
<b>MASTERPACK</b>	Length: 275 mm	Length: 320 mm	Length: 357 mm	Length: 275 mm
<b>DIMENSIONS</b>	Width: 185 mm	Width: 220 mm	Width: 240 mm	Width: 185 mm
	Height: 270 mm	Height: 270 mm	Height: 270 mm	Height: 270 mm
	Weight: 936 gr	Weight: 1041 gr	Weight: 1247 gr	Weight: 936 gr
<b>EURO PALLET</b>	Bill units/pallet: 672	Bill units/pallet: 504	Bill units/pallet: 378	Bill units/pallet: 672
	Bill units/layer: 96	Bill units/layer: 72	Bill units/layer: 54	Bill units/layer: 96
	Layers/pallet: 7	Layers/pallet: 7	Layers/pallet: 7	Layers/pallet: 7
<b>CONTAINER PALLET</b>	Bill units/pallet: 1104	Bill units/pallet: 768	Bill units/pallet: 624	Bill units/pallet: 1104
<b>HIGH CUBE</b>	Bill units/layer: 138	Bill units/layer: 96	Bill units/layer: 78	Bill units/layer: 138
	Layers/pallet: 8	Layers/pallet: 8	Layers/pallet: 8	Layers/pallet: 8
<b>EAN BILL UNIT</b>	 9 006206 324279	 9 006206 324316	 9 006206 324309	 9 006206 324262





Cabernet/Merlot



Pinot Noir/Nebbiolo



Syrah



Champagne Wine Glass

<b>ITEM</b>	Item no.: 0123/0 <b>fine crystal premium machine-made</b> Height/glass: 250 mm Capacity/glass: 1002 ccm Design: 2020	Item no.: 0123/07 <b>fine crystal premium machine-made</b> Height/glass: 250 mm Capacity/glass: 950 ccm Design: 2020	Item no.: 0123/41 <b>fine crystal premium machine-made</b> Height/glass: 250 mm Capacity/glass: 865 ccm Design: 2020	Item no.: 0123/28 <b>fine crystal premium machine-made</b> Height/glass: 250 mm Capacity/glass: 742 ccm Design: 2020
<b>PACKAGING</b>	Pieces/Bill unit: 1	Pieces/Bill unit: 1	Pieces/Bill unit: 1	Pieces/Bill unit: 1
<b>TYPE AND QUANTITY</b>	Bill units/MP: 6	Bill units/MP: 6	Bill units/MP: 6	Bill units/MP: 6
<b>MASTERPACK</b>	Length: 374 mm	Length: 374 mm	Length: 342 mm	Length: 342 mm
<b>DIMENSIONS</b>	Width: 251 mm	Width: 251 mm	Width: 230 mm	Width: 230 mm
	Height: 267 mm	Height: 267 mm	Height: 264 mm	Height: 264 mm
	Weight: 1432 gr	Weight: 1385 gr	Weight: 1442 gr	Weight: 1388 gr
<b>EURO PALLET</b>	Bill units/pallet: 378	Bill units/pallet: 378	Bill units/pallet: 420	Bill units/pallet: 420
	Bill units/layer: 54	Bill units/layer: 54	Bill units/layer: 60	Bill units/layer: 60
	Layers/pallet: 7	Layers/pallet: 7	Layers/pallet: 7	Layers/pallet: 7
<b>CONTAINER PALLET</b>	Bill units/pallet: 576	Bill units/pallet: 576	Bill units/pallet: 720	Bill units/pallet: 720
<b>HIGH CUBE</b>	Bill units/layer: 72	Bill units/layer: 72	Bill units/layer: 90	Bill units/layer: 90
	Layers/pallet: 8	Layers/pallet: 8	Layers/pallet: 8	Layers/pallet: 8
<b>EAN</b>				
<b>BILL UNIT</b>	9 006206 531363	9 006206 531370	9 006206 531417	9 006206 531394





Riesling



Sauvignon Blanc



Chardonnay

<b>ITEM</b>	<b>Item no.:</b> 0123/15 <b>fine crystal premium machine-made</b>	<b>Item no.:</b> 0123/33 <b>fine crystal premium machine-made</b>	<b>Item no.:</b> 0123/97 <b>fine crystal premium machine-made</b>
	Height/glass: 250 mm Capacity/glass: 1017 ccm Design: 2020	Height/glass: 250 mm Capacity/glass: 742 ccm Design: 2020	Height/glass: 250 mm Capacity/glass: 736 ccm Design: 2020
<b>PACKAGING</b>	Pieces/Bill unit: 1	Pieces/Bill unit: 1	Pieces/Bill unit: 1
<b>TYPE AND QUANTITY</b>	Bill units/MP: 6	Bill units/MP: 6	Bill units/MP: 6
<b>MASTERPACK</b>	Length: 374 mm	Length: 342 mm	Length: 342 mm
<b>DIMENSIONS</b>	Width: 251 mm	Width: 230 mm	Width: 230 mm
	Height: 267 mm	Height: 264 mm	Height: 264 mm
	Weight: 1415 gr	Weight: 1370 gr	Weight: 1358 gr
<b>EURO PALLET</b>	Bill units/pallet: 378	Bill units/pallet: 420	Bill units/pallet: 420
	Bill units/layer: 54	Bill units/layer: 60	Bill units/layer: 60
	Layers/pallet: 7	Layers/pallet: 7	Layers/pallet: 7
<b>CONTAINER PALLET</b>	Bill units/pallet: 576	Bill units/pallet: 720	Bill units/pallet: 720
<b>HIGH CUBE</b>	Bill units/layer: 72	Bill units/layer: 90	Bill units/layer: 90
	Layers/pallet: 8	Layers/pallet: 8	Layers/pallet: 8
<b>EAN BILL UNIT</b>	 9 006206 531387	 9 006206 531400	 9 006206 531424





Cabernet/Merlot



Pinot Noir



Syrah/Shiraz



Champagne Glass

ITEM	Item no.: 0884/0 fine crystal premium machine-made	Item no.: 0884/67 fine crystal premium machine-made	Item no.: 0884/41 fine crystal premium machine-made	Item no.: 0884/28 fine crystal premium machine-made
	Height/glass: 245 mm Capacity/glass: 834 ccm Design: 2018	Height/glass: 245 mm Capacity/glass: 830 ccm Design: 2018	Height/glass: 245 mm Capacity/glass: 631 ccm Design: 2018	Height/glass: 245 mm Capacity/glass: 375 ccm Design: 2018
<b>PACKAGING</b>	Pieces/Bill unit: 1	Pieces/Bill unit: 1	Pieces/Bill unit: 1	Pieces/Bill unit: 1
<b>TYPE AND QUANTITY</b>	Bill units/MP: 6	Bill units/MP: 6	Bill units/MP: 6	Bill units/MP: 6
<b>MASTERPACK</b>	Length: 334 mm	Length: 344 mm	Length: 319 mm	Length: 289 mm
<b>DIMENSIONS</b>	Width: 224 mm	Width: 231 mm	Width: 215 mm	Width: 194 mm
	Height: 268 mm	Height: 267 mm	Height: 267 mm	Height: 267 mm
	Weight: 1295 gr	Weight: 1303 gr	Weight: 1245 gr	Weight: 1082 gr
<b>EURO PALLET</b>	Bill units/pallet: 462	Bill units/pallet: 420	Bill units/pallet: 504	Bill units/pallet: 672
	Bill units/layer: 66	Bill units/layer: 60	Bill units/layer: 72	Bill units/layer: 96
	Layers/pallet: 7	Layers/pallet: 7	Layers/pallet: 7	Layers/pallet: 7
<b>CONTAINER PALLET</b>	Bill units/pallet: 720	Bill units/pallet: 720	Bill units/pallet: 864	Bill units/pallet: 1056
<b>HIGH CUBE</b>	Bill units/layer: 90	Bill units/layer: 90	Bill units/layer: 108	Bill units/layer: 132
	Layers/pallet: 8	Layers/pallet: 8	Layers/pallet: 8	Layers/pallet: 8
<b>EAN</b>				
<b>BILL UNIT</b>	9 006206 527564	9 006206 527540	9 006206 527595	9 006206 527557









Sauvignon Blanc



Riesling



Chardonnay

<b>ITEM</b>	<b>Item no.:</b> 0884/33 <b>fine crystal premium machine-made</b>	<b>Item no.:</b> 0884/15 <b>fine crystal premium machine-made</b>	<b>Item no.:</b> 0884/97 <b>fine crystal premium machine-made</b>
	Height/glass: 245 mm Capacity/glass: 440 ccm Design: 2019	Height/glass: 245 mm Capacity/glass: 623 ccm Design: 2018	Height/glass: 245 mm Capacity/glass: 727 ccm Design: 2018
<b>PACKAGING</b>	Pieces/Bill unit: 1	Pieces/Bill unit: 1	Pieces/Bill unit: 1
<b>TYPE AND QUANTITY</b>	Bill units/MP: 6	Bill units/MP: 6	Bill units/MP: 6
<b>MASTERPACK</b>	Length: 289 mm	Length: 319 mm	Length: 344 mm
<b>DIMENSIONS</b>	Width: 194 mm	Width: 215 mm	Width: 231 mm
	Height: 267 mm	Height: 267 mm	Height: 267 mm
	Weight: 1142 gr	Weight: 1181 gr	Weight: 1303 gr
<b>EURO PALLET</b>	Bill units/pallet: 672	Bill units/pallet: 504	Bill units/pallet: 420
	Bill units/layer: 96	Bill units/layer: 72	Bill units/layer: 60
	Layers/pallet: 7	Layers/pallet: 7	Layers/pallet: 7
<b>CONTAINER PALLET</b>	Bill units/pallet: 1056	Bill units/pallet: 864	Bill units/pallet: 720
<b>HIGH CUBE</b>	Bill units/layer: 132	Bill units/layer: 108	Bill units/layer: 90
	Layers/pallet: 8	Layers/pallet: 8	Layers/pallet: 8
<b>EAN BILL UNIT</b>	 9 006206 529414	 9 006206 527533	 9 006206 527588





New World Shiraz



Cabernet/Merlot



Old World Pinot Noir



Old World Syrah

ITEM	Item no.: 0449/30 fine crystal premium machine-made	Item no.: 0449/0 fine crystal premium machine-made	Item no.: 0449/07 fine crystal premium machine-made	Item no.: 0449/41 fine crystal premium machine-made
	Height/glass: 246 mm Capacity/glass: 650 ccm Design: 2014	Height/glass: 235 mm Capacity/glass: 625 ccm Design: 2014	Height/glass: 235 mm Capacity/glass: 705 ccm Design: 2014	Height/glass: 235 mm Capacity/glass: 600 ccm Design: 2014
<b>PACKAGING</b>	Pieces/Bill unit: 1	Pieces/Bill unit: 1	Pieces/Bill unit: 1	Pieces/Bill unit: 1
<b>TYPE AND QUANTITY</b>	Bill units/MP: 6	Bill units/MP: 6	Bill units/MP: 6	Bill units/MP: 6
<b>MASTERPACK</b>	Length: 305 mm	Length: 305 mm	Length: 342 mm	Length: 305 mm
<b>DIMENSIONS</b>	Width: 206 mm	Width: 206 mm	Width: 230 mm	Width: 206 mm
	Height: 277 mm	Height: 264 mm	Height: 265 mm	Height: 264 mm
	Weight: 1240 gr	Weight: 1177 gr	Weight: 1274 gr	Weight: 1226 gr
<b>EURO PALLET</b>	Bill units/pallet: 432	Bill units/pallet: 504	Bill units/pallet: 420	Bill units/pallet: 504
	Bill units/layer: 72	Bill units/layer: 72	Bill units/layer: 60	Bill units/layer: 72
	Layers/pallet: 6	Layers/pallet: 7	Layers/pallet: 7	Layers/pallet: 7
<b>CONTAINER PALLET</b>	Bill units/pallet: 960	Bill units/pallet: 960	Bill units/pallet: 720	Bill units/pallet: 960
<b>HIGH CUBE</b>	Bill units/layer: 120	Bill units/layer: 120	Bill units/layer: 90	Bill units/layer: 120
	Layers/pallet: 8	Layers/pallet: 8	Layers/pallet: 8	Layers/pallet: 8
<b>EAN</b>				
<b>BILL UNIT</b>	9 006206 523269	9 006206 523207	9 006206 523221	9 006206 523276



RIEDEL VERITAS  
 GRAPE VARIETAL SPECIFIC®  
 —RESTAURANT—



New World Pinot Noir/Nebbiolo/Rosé  
Champagne Glass







Champagne Wine Glass



Riesling/Zinfandel



Sauvignon Blanc

<b>ITEM</b>	<b>Item no.:</b> 0449/67 <b>fine crystal premium machine-made</b>	<b>Item no.:</b> 0449/28 <b>fine crystal premium machine-made</b>	<b>Item no.:</b> 0449/15 <b>fine crystal premium machine-made</b>	<b>Item no.:</b> 0449/33 <b>fine crystal premium machine-made</b>
	Height/glass: 235 mm Capacity/glass: 800 ccm Design: 2014	Height/glass: 235 mm Capacity/glass: 445 ccm Design: 2014	Height/glass: 235 mm Capacity/glass: 395 ccm Design: 2014	Height/glass: 235 mm Capacity/glass: 440 ccm Design: 2017
<b>PACKAGING TYPE AND QUANTITY</b>	Pieces/Bill unit: 1 Bill units/MP: 6	Pieces/Bill unit: 1 Bill units/MP: 6	Pieces/Bill unit: 1 Bill units/MP: 6	Pieces/Bill unit: 1 Bill units/MP: 6
<b>MASTERPACK DIMENSIONS</b>	Length: 342 mm Width: 230 mm Height: 265 mm Weight: 1411 gr	Length: 277 mm Width: 186 mm Height: 265 mm Weight: 1089 gr	Length: 263 mm Width: 176 mm Height: 265 mm Weight: 1063 gr	Length: 277 mm Width: 186 mm Height: 265 mm Weight: 1029 gr
<b>EURO PALLET</b>	Bill units/pallet: 420 Bill units/layer: 60 Layers/pallet: 7	Bill units/pallet: 672 Bill units/layer: 96 Layers/pallet: 7	Bill units/pallet: 798 Bill units/layer: 114 Layers/pallet: 7	Bill units/pallet: 672 Bill units/layer: 96 Layers/pallet: 7
<b>CONTAINER PALLET HIGH CUBE</b>	Bill units/pallet: 720 Bill units/layer: 90 Layers/pallet: 8	Bill units/pallet: 1104 Bill units/layer: 138 Layers/pallet: 8	Bill units/pallet: 1248 Bill units/layer: 156 Layers/pallet: 8	Bill units/pallet: 1104 Bill units/layer: 138 Layers/pallet: 8
<b>EAN BILL UNIT</b>	 9 006206 523283	 9 006206 523252	 9 006206 523245	 9 006206 526055



Viognier/Chardonnay







Oaked Chardonnay



Coupe/Cocktail



Spirits

ITEM	Item no.: 0449/05 fine crystal premium machine-made	Item no.: 0449/97 fine crystal premium machine-made	Item no.: 0449/09 fine crystal premium machine-made	Item no.: 0449/71 fine crystal premium machine-made
	Height/glass: 225 mm Capacity/glass: 370 ccm Design: 2014	Height/glass: 217 mm Capacity/glass: 620 ccm Design: 2014	Height/glass: 170 mm Capacity/glass: 240 ccm Design: 2014	Height/glass: 235 mm Capacity/glass: 152 ccm Design: 2016
<b>PACKAGING</b>	Pieces/Bill unit: 1	Pieces/Bill unit: 1	Pieces/Bill unit: 1	Pieces/Bill unit: 1
<b>TYPE AND QUANTITY</b>	Bill units/MP: 6	Bill units/MP: 6	Bill units/MP: 6	Bill units/MP: 6
<b>MASTERPACK</b>	Length: 264 mm	Length: 338 mm	Length: 336 mm	Length: 265 mm
<b>DIMENSIONS</b>	Width: 183 mm	Width: 229 mm	Width: 225 mm	Width: 179 mm
	Height: 255 mm	Height: 245 mm	Height: 199 mm	Height: 263 mm
	Weight: 1042 gr	Weight: 1224 gr	Weight: 1020 gr	Weight: 957 gr
<b>EURO PALLET</b>	Bill units/pallet: 798	Bill units/pallet: 462	Bill units/pallet: 594	Bill units/pallet: 798
	Bill units/layer: 114	Bill units/layer: 66	Bill units/layer: 66	Bill units/layer: 114
	Layers/pallet: 7	Layers/pallet: 7	Layers/pallet: 9	Layers/pallet: 7
<b>CONTAINER PALLET</b>	Bill units/pallet: 1350	Bill units/pallet: 810	Bill units/pallet: 990	Bill units/pallet: 1248
<b>HIGH CUBE</b>	Bill units/layer: 150	Bill units/layer: 90	Bill units/layer: 90	Bill units/layer: 156
	Layers/pallet: 9	Layers/pallet: 9	Layers/pallet: 11	Layers/pallet: 8
<b>EAN</b>				
<b>BILL UNIT</b>	9 006206 523214	9 006206 523290	9 006206 523238	9 006206 525355



Beer

<b>ITEM</b>	<b>Item no.:</b> 0449/11 <b>fine crystal</b> <b>premium machine-made</b>
	Height/glass: 160 mm Capacity/glass: 435 ccm Design: 2016
<b>PACKAGING</b>	Pieces/Bill unit: 1
<b>TYPE AND QUANTITY</b>	Bill units/MP: 6
<b>MASTERPACK</b>	Length: 274 mm
<b>DIMENSIONS</b>	Width: 184 mm Height: 186 mm Weight: 954 gr
<b>EURO PALLET</b>	Bill units/pallet: 1020 Bill units/layer: 102 Layers/pallet: 10
<b>CONTAINER PALLET</b>	Bill units/pallet: 1656
<b>HIGH CUBE</b>	Bill units/layer: 138 Layers/pallet: 12
<b>EAN</b> <b>BILL UNIT</b>	 9 006206 525331



Syrah/Shiraz/Tempranillo



Cabernet Sauvignon/Merlot



Pinot Noir (Burgundy Red)



Zinfandel

ITEM	Item no.: 0416/30-6 fine crystal premium machine-made	Item no.: 0416/0-6 fine crystal premium machine-made	Item no.: 0416/07-6 fine crystal premium machine-made	Item no.: 0416/15-6 fine crystal premium machine-made
	Height/glass: 236 mm Capacity/glass: 700 ccm Design: 1995	Height/glass: 225 mm Capacity/glass: 610 ccm Design: 1986	Height/glass: 210 mm Capacity/glass: 700 ccm Design: 1986	Height/glass: 210 mm Capacity/glass: 400 ccm Design: 1992
<b>PACKAGING</b>	Pieces/Bill unit: 1	Pieces/Bill unit: 1	Pieces/Bill unit: 1	Pieces/Bill unit: 1
<b>TYPE AND QUANTITY</b>	Bill units/MP: 6	Bill units/MP: 6	Bill units/MP: 6	Bill units/MP: 6
<b>MASTERPACK</b>	Length: 305 mm	Length: 305 mm	Length: 342 mm	Length: 256 mm
<b>DIMENSIONS</b>	Width: 205 mm	Width: 205 mm	Width: 231 mm	Width: 174 mm
	Height: 261 mm	Height: 255 mm	Height: 241 mm	Height: 242 mm
	Weight: 1328 gr	Weight: 1271 gr	Weight: 1347 gr	Weight: 1089 gr
<b>EURO PALLET</b>	Bill units/pallet: 504	Bill units/pallet: 504	Bill units/pallet: 420	Bill units/pallet: 840
	Bill units/layer: 72	Bill units/layer: 72	Bill units/layer: 60	Bill units/layer: 120
	Layers/pallet: 7	Layers/pallet: 7	Layers/pallet: 7	Layers/pallet: 7
<b>CONTAINER PALLET</b>	Bill units/pallet: 960	Bill units/pallet: 1080	Bill units/pallet: 810	Bill units/pallet: 1512
<b>HIGH CUBE</b>	Bill units/layer: 120	Bill units/layer: 120	Bill units/layer: 90	Bill units/layer: 168
	Layers/pallet: 8	Layers/pallet: 9	Layers/pallet: 9	Layers/pallet: 9
<b>EAN</b>				
<b>BILL UNIT</b>	9 006206 510030	9 006206 510016	9 006206 510023	9 006206 510047



Riesling Grand Cru



Viognier/Chardonnay



Champagne Wine Glass



Cuvée Prestige

ITEM	Item no.: 0416/15-6 <b>fine crystal premium machine-made</b>	Item no.: 0416/05-6 <b>fine crystal premium machine-made</b>	Item no.: 0416/58-6 <b>fine crystal premium machine-made</b>	Item no.: 0416/48-6 <b>fine crystal premium machine-made</b>
	Height/glass: 210 mm	Height/glass: 198 mm	Height/glass: 225 mm	Height/glass: 218 mm
	Capacity/glass: 400 ccm	Capacity/glass: 350 ccm	Capacity/glass: 445 ccm	Capacity/glass: 230 ccm
	Design: 1992	Design: 1986	Design: 2018	Design: 1999
<b>PACKAGING</b>	Pieces/Bill unit: 1	Pieces/Bill unit: 1	Pieces/Bill unit: 1	Pieces/Bill unit: 1
<b>TYPE AND QUANTITY</b>	Bill units/MP: 6	Bill units/MP: 6	Bill units/MP: 6	Bill units/MP: 6
<b>MASTERPACK</b>	Length: 256 mm	Length: 260 mm	Length: 277 mm	Length: 227 mm
<b>DIMENSIONS</b>	Width: 174 mm	Width: 175 mm	Width: 185 mm	Width: 154 mm
	Height: 242 mm	Height: 228 mm	Height: 241 mm	Height: 248 mm
	Weight: 1089 gr	Weight: 1044 gr	Weight: 1275 gr	Weight: 959 gr
<b>EURO PALLET</b>	Bill units/pallet: 840	Bill units/pallet: 912	Bill units/pallet: 672	Bill units/pallet: 1050
	Bill units/layer: 120	Bill units/layer: 114	Bill units/layer: 96	Bill units/layer: 150
	Layers/pallet: 7	Layers/pallet: 8	Layers/pallet: 7	Layers/pallet: 7
<b>CONTAINER PALLET</b>	Bill units/pallet: 1512	Bill units/pallet: 1680	Bill units/pallet: 1242	Bill units/pallet: 1944
<b>HIGH CUBE</b>	Bill units/layer: 168	Bill units/layer: 168	Bill units/layer: 138	Bill units/layer: 216
	Layers/pallet: 9	Layers/pallet: 10	Layers/pallet: 9	Layers/pallet: 9
<b>EAN BILL UNIT</b>	 9 006206 510047	 9 006206 510054	 9 006206 527526	 9 006206 510122



Cabernet



Pinot Noir



Shiraz



Riesling/Sauvignon Blanc

ITEM	Item no.: fine crystal machine-made	0454/0	Item no.: fine crystal machine-made	0454/07	Item no.: fine crystal machine-made	0454/32	Item no.: fine crystal machine-made	0454/05
	Height/glass:	247 mm	Height/glass:	243 mm	Height/glass:	244 mm	Height/glass:	240 mm
	Capacity/glass:	800 ccm	Capacity/glass:	770 ccm	Capacity/glass:	709 ccm	Capacity/glass:	490 ccm
	Design:	2017	Design:	2017	Design:	2017	Design:	2017
<b>PACKAGING</b>	Pieces/Bill unit:	1	Pieces/Bill unit:	1	Pieces/Bill unit:	1	Pieces/Bill unit:	1
<b>TYPE AND QUANTITY</b>	Bill units/MP:	12	Bill units/MP:	12	Bill units/MP:	12	Bill units/MP:	12
<b>MASTERPACK</b>	Length:	443 mm	Length:	479 mm	Length:	443 mm	Length:	371 mm
<b>DIMENSIONS</b>	Width:	330 mm	Width:	357 mm	Width:	330 mm	Width:	276 mm
	Height:	261 mm	Height:	257 mm	Height:	261 mm	Height:	254 mm
	Weight:	2806 gr	Weight:	3011 gr	Weight:	2822 gr	Weight:	2458 gr
<b>EURO PALLET</b>	Bill units/pallet:	420	Bill units/pallet:	336	Bill units/pallet:	420	Bill units/pallet:	672
	Bill units/layer:	60	Bill units/layer:	48	Bill units/layer:	60	Bill units/layer:	96
	Layers/pallet:	7	Layers/pallet:	7	Layers/pallet:	7	Layers/pallet:	7
<b>CONTAINER PALLET</b>	Bill units/pallet:	768	Bill units/pallet:	648	Bill units/pallet:	768	Bill units/pallet:	1188
<b>HIGH CUBE</b>	Bill units/layer:	96	Bill units/layer:	72	Bill units/layer:	96	Bill units/layer:	132
	Layers/pallet:	8	Layers/pallet:	9	Layers/pallet:	8	Layers/pallet:	9
<b>EAN</b>								
<b>BILL UNIT</b>	9 006206 513000		9 006206 513024		9 006206 312689		9 006206 513017	







Rosé Wine







Oaked Chardonnay



Prosecco Superiore



Martini

ITEM	Item no.: fine crystal machine-made	0454/55	Item no.: fine crystal machine-made	0454/97	Item no.: fine crystal machine-made	0454/85	Item no.: fine crystal machine-made	0454/17
	Height/glass:	230 mm	Height/glass:	227 mm	Height/glass:	222 mm	Height/glass:	175 mm
	Capacity/glass:	322 ccm	Capacity/glass:	670 ccm	Capacity/glass:	305 ccm	Capacity/glass:	250 ccm
	Design:	2017	Design:	2017	Design:	2017	Design:	2017
<b>PACKAGING</b>	Pieces/Bill unit:	1	Pieces/Bill unit:	1	Pieces/Bill unit:	1	Pieces/Bill unit:	1
<b>TYPE AND QUANTITY</b>	Bill units/MP:	12	Bill units/MP:	12	Bill units/MP:	12	Bill units/MP:	12
<b>MASTERPACK</b>	Length:	371 mm	Length:	479 mm	Length:	371 mm	Length:	479 mm
<b>DIMENSIONS</b>	Width:	276 mm	Width:	357 mm	Width:	276 mm	Width:	357 mm
	Height:	254 mm	Height:	251 mm	Height:	254 mm	Height:	257 mm
	Weight:	2269 gr	Weight:	2770 gr	Weight:	2349 gr	Weight:	2741 gr
<b>EURO PALLET</b>	Bill units/pallet:	672	Bill units/pallet:	336	Bill units/pallet:	672	Bill units/pallet:	336
	Bill units/layer:	96	Bill units/layer:	48	Bill units/layer:	96	Bill units/layer:	48
	Layers/pallet:	7	Layers/pallet:	7	Layers/pallet:	7	Layers/pallet:	7
<b>CONTAINER PALLET</b>	Bill units/pallet:	1188	Bill units/pallet:	648	Bill units/pallet:	1188	Bill units/pallet:	648
<b>HIGH CUBE</b>	Bill units/layer:	132	Bill units/layer:	72	Bill units/layer:	132	Bill units/layer:	72
	Layers/pallet:	9	Layers/pallet:	9	Layers/pallet:	9	Layers/pallet:	9
<b>EAN</b>	 9 006206 524105		 9 006206 513031		 9 006206 524112		 9 006206 513048	
<b>BILL UNIT</b>								



Bordeaux Grand Cru



Old World Syrah



New World Pinot Noir



New World Shiraz

ITEM	Item no.: 0447/00 fine crystal machine-made	Item no.: 0447/30 fine crystal machine-made	Item no.: 0447/07 fine crystal machine-made	Item no.: 0446/30 fine crystal machine-made
	Height/glass: 255 mm Capacity/glass: 960 ccm Design: 2010	Height/glass: 238 mm Capacity/glass: 640 ccm Design: 2010	Height/glass: 229 mm Capacity/glass: 850 ccm Design: 2010	Height/glass: 226 mm Capacity/glass: 650 ccm Design: 2002
<b>PACKAGING</b>	Pieces/Bill unit: 1	Pieces/Bill unit: 1	Pieces/Bill unit: 1	Pieces/Bill unit: 1
<b>TYPE AND QUANTITY</b>	Bill units/MP: 12	Bill units/MP: 12	Bill units/MP: 12	Bill units/MP: 12
<b>MASTERPACK</b>	Length: 455 mm	Length: 410 mm	Length: 444 mm	Length: 444 mm
<b>DIMENSIONS</b>	Width: 339 mm	Width: 306 mm	Width: 332 mm	Width: 332 mm
	Height: 270 mm	Height: 252 mm	Height: 243 mm	Height: 243 mm
	Weight: 3117 gr	Weight: 3005 gr	Weight: 2600 gr	Weight: 2552 gr
<b>EURO PALLET</b>	Bill units/pallet: 420	Bill units/pallet: 504	Bill units/pallet: 420	Bill units/pallet: 420
	Bill units/layer: 60	Bill units/layer: 72	Bill units/layer: 60	Bill units/layer: 60
	Layers/pallet: 7	Layers/pallet: 7	Layers/pallet: 7	Layers/pallet: 7
<b>CONTAINER PALLET</b>	Bill units/pallet: 672	Bill units/pallet: 972	Bill units/pallet: 864	Bill units/pallet: 864
<b>HIGH CUBE</b>	Bill units/layer: 84	Bill units/layer: 108	Bill units/layer: 96	Bill units/layer: 96
	Layers/pallet: 8	Layers/pallet: 9	Layers/pallet: 9	Layers/pallet: 9
<b>EAN BILL UNIT</b>				

REBSORTEN SPEZIFISCH®

RIEDEL

—RESTAURANT—



Cabernet/Merlot







Old World Pinot Noir



Zinfandel



Champagne Glass

<b>ITEM</b>	<b>Item no.:</b> 0446/0 <b>fine crystal machine-made</b>	<b>Item no.:</b> 0446/07 <b>fine crystal machine-made</b>	<b>Item no.:</b> 0446/15 <b>fine crystal machine-made</b>	<b>Item no.:</b> 0446/48 <b>fine crystal machine-made</b>
	Height/glass: 217 mm	Height/glass: 215 mm	Height/glass: 214 mm	Height/glass: 217 mm
	Capacity/glass: 610 ccm	Capacity/glass: 700 ccm	Capacity/glass: 370 ccm	Capacity/glass: 260 ccm
	Design: 2001	Design: 2001	Design: 2002	Design: 2001
<b>PACKAGING</b>	Pieces/Bill unit: 1	Pieces/Bill unit: 1	Pieces/Bill unit: 1	Pieces/Bill unit: 1
<b>TYPE AND QUANTITY</b>	Bill units/MP: 12	Bill units/MP: 12	Bill units/MP: 12	Bill units/MP: 12
<b>MASTERPACK</b>	Length: 444 mm	Length: 444 mm	Length: 368 mm	Length: 295 mm
<b>DIMENSIONS</b>	Width: 332 mm	Width: 332 mm	Width: 275 mm	Width: 219 mm
	Height: 243 mm	Height: 243 mm	Height: 244 mm	Height: 232 mm
	Weight: 2642 gr	Weight: 2614 gr	Weight: 2130 gr	Weight: 1865 gr
<b>EURO PALLET</b>	Bill units/pallet: 420	Bill units/pallet: 420	Bill units/pallet: 672	Bill units/pallet: 1248
	Bill units/layer: 60	Bill units/layer: 60	Bill units/layer: 96	Bill units/layer: 156
	Layers/pallet: 7	Layers/pallet: 7	Layers/pallet: 7	Layers/pallet: 8
<b>CONTAINER PALLET</b>	Bill units/pallet: 864	Bill units/pallet: 864	Bill units/pallet: 1188	Bill units/pallet: 2160
<b>HIGH CUBE</b>	Bill units/layer: 96	Bill units/layer: 96	Bill units/layer: 132	Bill units/layer: 216
	Layers/pallet: 9	Layers/pallet: 9	Layers/pallet: 9	Layers/pallet: 10
<b>EAN BILL UNIT</b>	 9 006206 511761	 9 006206 511747	 9 006206 511730	 9 006206 511945

THIS GLASS IS ALSO AVAILABLE  
WITH CALIBRATION MARK.

THIS GLASS IS ALSO AVAILABLE  
WITH CALIBRATION MARK.

THIS GLASS IS ALSO AVAILABLE  
WITH CALIBRATION MARK.



Riesling







Champagne Wine Glass



Viognier/Chardonnay



Oaked Chardonnay

<b>ITEM</b>	<b>Item no.:</b> 0446/15 <b>fine crystal machine-made</b>	<b>Item no.:</b> 0446/58 <b>fine crystal machine-made</b>	<b>Item no.:</b> 0446/05 <b>fine crystal machine-made</b>	<b>Item no.:</b> 0446/97 <b>fine crystal machine-made</b>
	Height/glass: 214 mm Capacity/glass: 370 ccm Design: 2002	Height/glass: 221 mm Capacity/glass: 440 ccm Design: 2018	Height/glass: 203 mm Capacity/glass: 350 ccm Design: 2001	Height/glass: 197 mm Capacity/glass: 700 ccm Design: 2001
<b>PACKAGING</b>	Pieces/Bill unit: 1	Pieces/Bill unit: 1	Pieces/Bill unit: 1	Pieces/Bill unit: 1
<b>TYPE AND QUANTITY</b>	Bill units/MP: 12	Bill units/MP: 12	Bill units/MP: 12	Bill units/MP: 12
<b>MASTERPACK</b>	Length: 368 mm	Length: 367 mm	Length: 368 mm	Length: 444 mm
<b>DIMENSIONS</b>	Width: 275 mm	Width: 271 mm	Width: 275 mm	Width: 332 mm
	Height: 244 mm	Height: 230 mm	Height: 244 mm	Height: 243 mm
	Weight: 2130 gr	Weight: 2304 gr	Weight: 2102 gr	Weight: 2695 gr
<b>EURO PALLET</b>	Bill units/pallet: 672	Bill units/pallet: 768	Bill units/pallet: 672	Bill units/pallet: 420
	Bill units/layer: 96	Bill units/layer: 96	Bill units/layer: 96	Bill units/layer: 60
	Layers/pallet: 7	Layers/pallet: 8	Layers/pallet: 7	Layers/pallet: 7
<b>CONTAINER PALLET</b>	Bill units/pallet: 1188	Bill units/pallet: 1320	Bill units/pallet: 1188	Bill units/pallet: 864
<b>HIGH CUBE</b>	Bill units/layer: 132	Bill units/layer: 132	Bill units/layer: 132	Bill units/layer: 96
	Layers/pallet: 9	Layers/pallet: 10	Layers/pallet: 9	Layers/pallet: 9
<b>EAN BILL UNIT</b>	 9 006206 511730	 9 006206 527335	 9 006206 511723	 9 006206 511754

THIS GLASS IS ALSO AVAILABLE WITH CALIBRATION MARK.

THIS GLASS IS ALSO AVAILABLE WITH CALIBRATION MARK.



Water

<b>ITEM</b>	<b>Item no.:</b>	0446/02
	<b>fine crystal machine-made</b>	
	Height/glass:	145 mm
	Capacity/glass:	350 ccm
	Design:	2001
<b>PACKAGING</b>	Pieces/Bill unit:	1
<b>TYPE AND QUANTITY</b>	Bill units/MP:	12
<b>MASTERPACK</b>	Length:	341 mm
<b>DIMENSIONS</b>	Width:	257 mm
	Height:	174 mm
	Weight:	1819 gr
<b>EURO PALLET</b>	Bill units/pallet:	1320
	Bill units/layer:	120
	Layers/pallet:	11
<b>CONTAINER PALLET</b>	Bill units/pallet:	2184
<b>HIGH CUBE</b>	Bill units/layer:	168
	Layers/pallet:	13
<b>EAN BILL UNIT</b>	 9 006206 511938	





Tequila





Rum/Aquavit



Cognac



Port

<b>ITEM</b>	<b>Item no.:</b> 0446/18 <b>fine crystal machine-made</b>	<b>Item no.:</b> 0512/10 <b>fine crystal machine-made</b>	<b>Item no.:</b> 0446/71 <b>fine crystal machine-made</b>	<b>Item no.:</b> 0446/60 <b>fine crystal machine-made</b>
	Height/glass: 210 mm Capacity/glass: 190 ccm Design: 2006	Height/glass: 205 mm Capacity/glass: 200 ccm Design: 2022	Height/glass: 190 mm Capacity/glass: 175 ccm Design: 2006	Height/glass: 176 mm Capacity/glass: 265 ccm Design: 2011
<b>PACKAGING</b>	Pieces/Bill unit: 1	Pieces/Bill unit: 1	Pieces/Bill unit: 1	Pieces/Bill unit: 1
<b>TYPE AND QUANTITY</b>	Bill units/MP: 12	Bill units/MP: 12	Bill units/MP: 12	Bill units/MP: 12
<b>MASTERPACK</b>	Length: 295 mm	Length: 340 mm	Length: 311 mm	Length: 319 mm
<b>DIMENSIONS</b>	Width: 219 mm	Width: 245 mm	Width: 230 mm	Width: 237 mm
	Height: 232 mm	Height: 220 mm	Height: 199 mm	Height: 193 mm
	Weight: 1745 gr	Weight: 1828 gr	Weight: 1765 gr	Weight: 1667 gr
<b>EURO PALLET</b>	Bill units/pallet: 1248	Bill units/pallet: 960	Bill units/pallet: 1296	Bill units/pallet: 1296
	Bill units/layer: 156	Bill units/layer: 120	Bill units/layer: 144	Bill units/layer: 144
	Layers/pallet: 8	Layers/pallet: 8	Layers/pallet: 9	Layers/pallet: 9
<b>CONTAINER PALLET</b>	Bill units/pallet: 2160	Bill units/pallet: 1680	Bill units/pallet: 2112	Bill units/pallet: 2304
<b>HIGH CUBE</b>	Bill units/layer: 216	Bill units/layer: 168	Bill units/layer: 192	Bill units/layer: 192
	Layers/pallet: 10	Layers/pallet: 10	Layers/pallet: 11	Layers/pallet: 12
<b>EAN BILL UNIT</b>	 9 006206 514861	 9 006206 323340	 9 006206 513963	 9 006206 516193



Beer





Single Malt Whisky



Whisky



Water

ITEM	Item no.: fine crystal machine-made	0446/11	Item no.: fine crystal machine-made	0446/80	Item no.: fine crystal machine-made	0480/02	Item no.: fine crystal machine-made	0480/01
	Height/glass:	170 mm	Height/glass:	113 mm	Height/glass:	100 mm	Height/glass:	80 mm
	Capacity/glass:	500 ccm	Capacity/glass:	200 ccm	Capacity/glass:	430 ccm	Capacity/glass:	330 ccm
	Design:	2002	Design:	2008	Design:	2009	Design:	2007
<b>PACKAGING</b>	Pieces/Bill unit:	1	Pieces/Bill unit:	1	Pieces/Bill unit:	1	Pieces/Bill unit:	1
<b>TYPE AND QUANTITY</b>	Bill units/MP:	12	Bill units/MP:	12	Bill units/MP:	12	Bill units/MP:	12
<b>MASTERPACK</b>	Length:	368 mm	Length:	295 mm	Length:	343 mm	Length:	343 mm
<b>DIMENSIONS</b>	Width:	275 mm	Width:	220 mm	Width:	254 mm	Width:	254 mm
	Height:	186 mm	Height:	128 mm	Height:	111 mm	Height:	111 mm
	Weight:	2276 gr	Weight:	1667 gr	Weight:	1828 gr	Weight:	1600 gr
<b>EURO PALLET</b>	Bill units/pallet:	960	Bill units/pallet:	2340	Bill units/pallet:	1920	Bill units/pallet:	1920
	Bill units/layer:	96	Bill units/layer:	156	Bill units/layer:	120	Bill units/layer:	120
	Layers/pallet:	10	Layers/pallet:	15	Layers/pallet:	16	Layers/pallet:	16
<b>CONTAINER PALLET</b>	Bill units/pallet:	1584	Bill units/pallet:	3888	Bill units/pallet:	3360	Bill units/pallet:	3360
<b>HIGH CUBE</b>	Bill units/layer:	132	Bill units/layer:	216	Bill units/layer:	168	Bill units/layer:	168
	Layers/pallet:	12	Layers/pallet:	18	Layers/pallet:	20	Layers/pallet:	20
<b>EAN</b>	 9 006206 511990		 9 006206 515455		 9 006206 515448		 9 006206 513208	
<b>BILL UNIT</b>								



All Purpose Glass



Neat Glass



Rocks Glass



Double Rocks Glass

ITEM	Item no.: fine crystal machine-made	0417/0	Item no.: fine crystal machine-made	0417/01	Item no.: fine crystal machine-made	0417/02	Item no.: fine crystal machine-made	0417/07
	Height/glass:	187 mm	Height/glass:	77 mm	Height/glass:	83 mm	Height/glass:	103 mm
	Capacity/glass:	350 ccm	Capacity/glass:	174 ccm	Capacity/glass:	283 ccm	Capacity/glass:	370 ccm
	Design:	2019	Design:	2019	Design:	2019	Design:	2022
<b>PACKAGING</b>	Pieces/Bill unit:	1	Pieces/Bill unit:	1	Pieces/Bill unit:	1	Pieces/Bill unit:	1
<b>TYPE AND QUANTITY</b>	Bill units/MP:	12	Bill units/MP:	12	Bill units/MP:	12	Bill units/MP:	12
<b>MASTERPACK</b>	Length:	335 mm	Length:	306 mm	Length:	356 mm	Length:	355 mm
<b>DIMENSIONS</b>	Width:	247 mm	Width:	230 mm	Width:	266 mm	Width:	265 mm
	Height:	196 mm	Height:	96 mm	Height:	103 mm	Height:	115 mm
	Weight:	1895 gr	Weight:	2936 gr	Weight:	4041 gr	Weight:	4915 gr
<b>EURO PALLET</b>	Bill units/pallet:	1080	Bill units/pallet:	1440	Bill units/pallet:	1080	Bill units/pallet:	1152
	Bill units/layer:	120	Bill units/layer:	144	Bill units/layer:	108	Bill units/layer:	96
	Layers/pallet:	9	Layers/pallet:	10	Layers/pallet:	10	Layers/pallet:	12
<b>CONTAINER PALLET</b>	Bill units/pallet:	1848	Bill units/pallet:	2304	Bill units/pallet:	1716	Bill units/pallet:	1452
<b>HIGH CUBE</b>	Bill units/layer:	168	Bill units/layer:	192	Bill units/layer:	156	Bill units/layer:	132
	Layers/pallet:	11	Layers/pallet:	12	Layers/pallet:	11	Layers/pallet:	11
<b>EAN</b>								
<b>BILL UNIT</b>	9 006206 529858		9 006206 528752		9 006206 528769		9 006206 323975	



# RIEDEL BAR

DRINK SPECIFIC GLASSWARE

GLASSES





Highball Glass



Fizz Glass



Nick & Nora Glass



Nick & Nora Glass Large

ITEM	Item no.: fine crystal machine-made	0417/04	Item no.: fine crystal machine-made	0417/03	Item no.: fine crystal machine-made	0417/05	Item no.: fine crystal premium machine-made	0417/08
	Height/glass:	154 mm	Height/glass:	163 mm	Height/glass:	153 mm	Height/glass:	177 mm
	Capacity/glass:	310 ccm	Capacity/glass:	265 ccm	Capacity/glass:	140 ccm	Capacity/glass:	198 ccm
	Design:	2019	Design:	2019	Design:	2019	Design:	2023
<b>PACKAGING</b>	Pieces/Bill unit:	1	Pieces/Bill unit:	1	Pieces/Bill unit:	1	Pieces/Bill unit:	1
<b>TYPE AND QUANTITY</b>	Bill units/MP:	12	Bill units/MP:	12	Bill units/MP:	12	Bill units/MP:	12
<b>MASTERPACK</b>	Length:	292 mm	Length:	267 mm	Length:	334 mm	Length:	348 mm
<b>DIMENSIONS</b>	Width:	219 mm	Width:	199 mm	Width:	245 mm	Width:	255 mm
	Height:	174 mm	Height:	179 mm	Height:	160 mm	Height:	183 mm
	Weight:	5455 gr	Weight:	5196 gr	Weight:	1586 gr	Weight:	1849 gr
<b>EURO PALLET</b>	Bill units/pallet:	936	Bill units/pallet:	1020	Bill units/pallet:	1440	Bill units/pallet:	1080
	Bill units/layer:	156	Bill units/layer:	204	Bill units/layer:	120	Bill units/layer:	108
	Layers/pallet:	6	Layers/pallet:	5	Layers/pallet:	12	Layers/pallet:	10
<b>CONTAINER PALLET</b>	Bill units/pallet:	1296	Bill units/pallet:	1152	Bill units/pallet:	2352	Bill units/pallet:	1872
<b>HIGH CUBE</b>	Bill units/layer:	216	Bill units/layer:	288	Bill units/layer:	168	Bill units/layer:	156
	Layers/pallet:	6	Layers/pallet:	4	Layers/pallet:	14	Layers/pallet:	12
<b>EAN</b>								
<b>BILL UNIT</b>	9 006206 528783		9 006206 528776		9 006206 528905		9 006206 325849	

**NEW**

**NEW**



Sour Glass







Sour Glass Optic



Coffee Glass



Mixing Glass

ITEM	Item no.: fine crystal machine-made	0417/06	Item no.: fine crystal premium machine-made	0417/09	Item no.: fine crystal machine-made	0417/10	Item no.: fine crystal machine-made	0417/23
	Height/glass:	158 mm	Height/glass:	158 mm	Height/glass:	63 mm	Height/glass:	176 mm
	Capacity/glass:	217 ccm	Capacity/glass:	215 ccm	Capacity/glass:	90 ccm	Capacity/glass:	650 ccm
	Design:	2019	Design:	2023	Design:	2023	Design:	2019
<b>PACKAGING</b>	Pieces/Bill unit:	1	Pieces/Bill unit:	1	Pieces/Bill unit:	1	Pieces/Bill unit:	1
<b>TYPE AND QUANTITY</b>	Bill units/MP:	12	Bill units/MP:	12	Bill units/MP:	12	Bill units/MP:	4
<b>MASTERPACK</b>	Length:	424 mm	Length:	402 mm	Length:	272 mm	Length:	92 mm
<b>DIMENSIONS</b>	Width:	315 mm	Width:	297 mm	Width:	205 mm	Width:	92 mm
	Height:	179 mm	Height:	176 mm	Height:	75 mm	Height:	189 mm
	Weight:	2065 gr	Weight:	2012 gr	Weight:	1628 gr	Weight:	884 gr
<b>EURO PALLET</b>	Bill units/pallet:	720	Bill units/pallet:	720	Bill units/pallet:	336	Bill units/pallet:	480
	Bill units/layer:	72	Bill units/layer:	72	Bill units/layer:	15	Bill units/layer:	96
	Layers/pallet:	10	Layers/pallet:	10	Layers/pallet:	19	Layers/pallet:	5
<b>CONTAINER PALLET</b>	Bill units/pallet:	1404	Bill units/pallet:	1440	Bill units/pallet:	336	Bill units/pallet:	600
<b>HIGH CUBE</b>	Bill units/layer:	108	Bill units/layer:	120	Bill units/layer:	21	Bill units/layer:	120
	Layers/pallet:	13	Layers/pallet:	12	Layers/pallet:	16	Layers/pallet:	5
<b>EAN</b>								
<b>BILL UNIT</b>	9 006206 528912		9 006206 325900		9 006206 326105		9 006206 529988	







Magnum  
RIEDEL 001



Red Wine  
RIEDEL 002



White Wine/Champagne Wine Glass  
RIEDEL 003

ITEM	Item no.: fine crystal machine-made	0260/0	Item no.: fine crystal machine-made	0260/02	Item no.: fine crystal machine-made	0260/03
	Height/glass:	261 mm	Height/glass:	247 mm	Height/glass:	221 mm
	Capacity/glass:	995 ccm	Capacity/glass:	667 ccm	Capacity/glass:	440 ccm
	Design:	2016	Design:	2020	Design:	2022
<b>PACKAGING</b>	Pieces/Bill unit:	1	Pieces/Bill unit:	1	Pieces/Bill unit:	1
<b>TYPE AND QUANTITY</b>	Bill units/MP:	12	Bill units/MP:	12	Bill units/MP:	12
<b>MASTERPACK</b>	Length:	462 mm	Length:	449 mm	Length:	367 mm
<b>DIMENSIONS</b>	Width:	345 mm	Width:	330 mm	Width:	271 mm
	Height:	273 mm	Height:	252 mm	Height:	230 mm
	Weight:	3497 gr	Weight:	2767 gr	Weight:	2304 gr
<b>EURO PALLET</b>	Bill units/pallet:	336	Bill units/pallet:	420	Bill units/pallet:	768
	Bill units/layer:	48	Bill units/layer:	60	Bill units/layer:	96
	Layers/pallet:	7	Layers/pallet:	7	Layers/pallet:	8
<b>CONTAINER PALLET</b>	Bill units/pallet:	672	Bill units/pallet:	756	Bill units/pallet:	1320
<b>HIGH CUBE</b>	Bill units/layer:	84	Bill units/layer:	84	Bill units/layer:	132
	Layers/pallet:	8	Layers/pallet:	9	Layers/pallet:	10
<b>EAN BILL UNIT</b>		9 006206 525270		9 006206 320639		9 006206 320981





Magnum



Red Wine



Champagne Glass



White Wine

ITEM	Item no.: fine crystal machine-made	0480/90	Item no.: fine crystal machine-made	0480/00	Item no.: fine crystal machine-made	0480/08	Item no.: fine crystal machine-made	0480/05
	Height/glass:	201 mm	Height/glass:	187 mm	Height/glass:	224 mm	Height/glass:	180 mm
	Capacity/glass:	530 ccm	Capacity/glass:	350 ccm	Capacity/glass:	290 ccm	Capacity/glass:	280 ccm
	Design:	2007	Design:	2007	Design:	2007	Design:	2007
<b>PACKAGING</b>	Pieces/Bill unit:	1	Pieces/Bill unit:	1	Pieces/Bill unit:	1	Pieces/Bill unit:	1
<b>TYPE AND QUANTITY</b>	Bill units/MP:	12	Bill units/MP:	12	Bill units/MP:	12	Bill units/MP:	12
<b>MASTERPACK</b>	Length:	379 mm	Length:	339 mm	Length:	307 mm	Length:	319 mm
<b>DIMENSIONS</b>	Width:	282 mm	Width:	252 mm	Width:	228 mm	Width:	237 mm
	Height:	215 mm	Height:	202 mm	Height:	239 mm	Height:	193 mm
	Weight:	2406 gr	Weight:	1981 gr	Weight:	1972 gr	Weight:	1756 gr
<b>EURO PALLET</b>	Bill units/pallet:	768	Bill units/pallet:	1080	Bill units/pallet:	1152	Bill units/pallet:	1296
	Bill units/layer:	96	Bill units/layer:	120	Bill units/layer:	144	Bill units/layer:	144
	Layers/pallet:	8	Layers/pallet:	9	Layers/pallet:	8	Layers/pallet:	9
<b>CONTAINER PALLET</b>	Bill units/pallet:	1320	Bill units/pallet:	1848	Bill units/pallet:	1944	Bill units/pallet:	2304
<b>HIGH CUBE</b>	Bill units/layer:	132	Bill units/layer:	168	Bill units/layer:	216	Bill units/layer:	192
	Layers/pallet:	10	Layers/pallet:	11	Layers/pallet:	9	Layers/pallet:	12
<b>EAN</b>								
<b>BILL UNIT</b>	9 006206 513161		9 006206 513178		9 006206 513192		9 006206 513185	



Red Wine







Champagne Flute



White Wine



Tumbler

ITEM	Item no.: 0489/0 <b>fine crystal machine-made</b>	Item no.: 0489/48 <b>fine crystal machine-made</b>	Item no.: 0489/01 <b>fine crystal machine-made</b>	Item no.: 0489/41 <b>fine crystal machine-made</b>
	Height/glass: 224 mm Capacity/glass: 560 ccm Design: 2010	Height/glass: 224 mm Capacity/glass: 212 ccm Design: 2015	Height/glass: 205 mm Capacity/glass: 340 ccm Design: 2010	Height/glass: 118 mm Capacity/glass: 570 ccm Design: 2014
<b>PACKAGING</b>	Pieces/Bill unit: 1	Pieces/Bill unit: 1	Pieces/Bill unit: 1	Pieces/Bill unit: 1
<b>TYPE AND QUANTITY</b>	Bill units/MP: 12	Bill units/MP: 12	Bill units/MP: 12	Bill units/MP: 12
<b>MASTERPACK</b>	Length: 377 mm	Length: 337 mm	Length: 338 mm	Length: 404 mm
<b>DIMENSIONS</b>	Width: 282 mm	Width: 251 mm	Width: 255 mm	Width: 303 mm
	Height: 242 mm	Height: 238 mm	Height: 224 mm	Height: 135 mm
	Weight: 2508 gr	Weight: 1990 gr	Weight: 1957 gr	Weight: 1666 gr
<b>EURO PALLET</b>	Bill units/pallet: 672	Bill units/pallet: 960	Bill units/pallet: 960	Bill units/pallet: 1008
	Bill units/layer: 96	Bill units/layer: 120	Bill units/layer: 120	Bill units/layer: 72
	Layers/pallet: 7	Layers/pallet: 8	Layers/pallet: 8	Layers/pallet: 14
<b>CONTAINER PALLET</b>	Bill units/pallet: 1188	Bill units/pallet: 1512	Bill units/pallet: 1680	Bill units/pallet: 2040
<b>HIGH CUBE</b>	Bill units/layer: 132	Bill units/layer: 168	Bill units/layer: 168	Bill units/layer: 120
	Layers/pallet: 9	Layers/pallet: 9	Layers/pallet: 10	Layers/pallet: 17
<b>EAN BILL UNIT</b>	 9 006206 515820	 9 006206 524273	 9 006206 515837	 9 006206 522606

THIS GLASS IS ALSO AVAILABLE  
WITH CALIBRATION MARK.

THIS GLASS IS ALSO AVAILABLE  
WITH CALIBRATION MARK.

**EXCLUDED FROM PROMOTIONS**



Optical „O“  
Whisky



Optical „O“  
Longdrink



RIEDEL Spey  
Single Old Fashioned



RIEDEL Spey  
Whisky

<b>ITEM</b>	<b>Item no.:</b> 0512/05 <b>fine crystal machine-made</b>	<b>Item no.:</b> 0512/90 <b>fine crystal machine-made</b>	<b>Item no.:</b> 0418/01 <b>fine crystal machine-made</b>	<b>Item no.:</b> 0418/02 <b>fine crystal machine-made</b>
	Height/glass: 96 mm Capacity/glass: 337 ccm Design: 2018	Height/glass: 113 mm Capacity/glass: 580 ccm Design: 2018	Height/glass: 80 mm Capacity/glass: 245 ccm Design: 2022	Height/glass: 102 mm Capacity/glass: 295 ccm Design: 2016
<b>PACKAGING</b>	Pieces/Bill unit: 1	Pieces/Bill unit: 1	Pieces/Bill unit: 1	Pieces/Bill unit: 1
<b>TYPE AND QUANTITY</b>	Bill units/MP: 12	Bill units/MP: 12	Bill units/MP: 12	Bill units/MP: 12
<b>MASTERPACK</b>	Length: 343 mm	Length: 404 mm	Length: 349 mm	Length: 398 mm
<b>DIMENSIONS</b>	Width: 254 mm	Width: 308 mm	Width: 263 mm	Width: 296 mm
	Height: 111 mm	Height: 140 mm	Height: 99 mm	Height: 133 mm
	Weight: 1444 gr	Weight: 2034 gr	Weight: 3942 gr	Weight: 5302 gr
<b>EURO PALLET</b>	Bill units/pallet: 1920	Bill units/pallet: 936	Bill units/pallet: 1080	Bill units/pallet: 672
	Bill units/layer: 120	Bill units/layer: 72	Bill units/layer: 108	Bill units/layer: 96
	Layers/pallet: 16	Layers/pallet: 13	Layers/pallet: 10	Layers/pallet: 7
<b>CONTAINER PALLET</b>	Bill units/pallet: 3360	Bill units/pallet: 1728	Bill units/pallet: 1716	Bill units/pallet: 1320
<b>HIGH CUBE</b>	Bill units/layer: 168	Bill units/layer: 108	Bill units/layer: 156	Bill units/layer: 120
	Layers/pallet: 20	Layers/pallet: 16	Layers/pallet: 11	Layers/pallet: 11
<b>EAN BILL UNIT</b>	 9 006206 527465	 9 006206 527458	 9 006206 528448	 9 006206 525263





RIEDEL Spey  
Longdrink







RIEDEL Fire  
Whisky



RIEDEL Fire  
Longdrink



RIEDEL Shadows  
Tumbler

ITEM	Item no.: 0418/04 <b>fine crystal machine-made</b>	Item no.: 0512/02S1 <b>fine crystal machine-made</b>	Item no.: 0512/04S1 <b>fine crystal machine-made</b>	Item no.: 0512/02S5 <b>fine crystal machine-made</b>
	Height/glass: 151 mm Capacity/glass: 395 ccm Design: 2018	Height/glass: 98 mm Capacity/glass: 295 ccm Design: 2018	Height/glass: 151 mm Capacity/glass: 375 ccm Design: 2018	Height/glass: 102 mm Capacity/glass: 323 ccm Design: 2019
<b>PACKAGING</b>	Pieces/Bill unit: 1	Pieces/Bill unit: 1	Pieces/Bill unit: 1	Pieces/Bill unit: 1
<b>TYPE AND QUANTITY</b>	Bill units/MP: 12	Bill units/MP: 12	Bill units/MP: 12	Bill units/MP: 12
<b>MASTERPACK</b>	Length: 350 mm	Length: 398 mm	Length: 350 mm	Length: 354 mm
<b>DIMENSIONS</b>	Width: 267 mm	Width: 296 mm	Width: 267 mm	Width: 265 mm
	Height: 190 mm	Height: 133 mm	Height: 190 mm	Height: 124 mm
	Weight: 6288 gr	Weight: 4102 gr	Weight: 5684 gr	Weight: 4875 gr
<b>EURO PALLET</b>	Bill units/pallet: 768	Bill units/pallet: 1344	Bill units/pallet: 960	Bill units/pallet: 972
	Bill units/layer: 96	Bill units/layer: 96	Bill units/layer: 96	Bill units/layer: 108
	Layers/pallet: 8	Layers/pallet: 14	Layers/pallet: 10	Layers/pallet: 9
<b>CONTAINER PALLET</b>	Bill units/pallet: 1008	Bill units/pallet: 1680	Bill units/pallet: 1092	Bill units/pallet: 1404
<b>HIGH CUBE</b>	Bill units/layer: 168	Bill units/layer: 120	Bill units/layer: 156	Bill units/layer: 156
	Layers/pallet: 6	Layers/pallet: 14	Layers/pallet: 7	Layers/pallet: 9
<b>EAN BILL UNIT</b>	 9 006206 527137	 9 006206 527472	 9 006206 527502	 9 006206 530137



Optical „O“  
All Purpose Glass

<b>ITEM</b>	<b>Item no.:</b> 0512/67 <b>fine crystal</b> <b>machine-made</b> Height/glass: 124 mm Capacity/glass: 765 ccm Design: 2019
<b>PACKAGING</b>	Pieces/Bill unit: 1
<b>TYPE AND QUANTITY</b>	Bill units/MP: 12
<b>MASTERPACK</b>	Length: 475 mm
<b>DIMENSIONS</b>	Width: 354 mm
	Height: 133 mm
	Weight: 1932 gr
<b>EURO PALLET</b>	Bill units/pallet: 672
	Bill units/layer: 48
	Layers/pallet: 14
<b>CONTAINER PALLET</b>	Bill units/pallet: 1428
<b>HIGH CUBE</b>	Bill units/layer: 84
	Layers/pallet: 17
<b>EAN</b> <b>BILL UNIT</b>	 9 006206 530052



RIEDEL Fire Whisky  
Baby Blue







RIEDEL Fire Whisky  
Red



RIEDEL Fire Whisky  
Yellow



RIEDEL Fire Whisky  
Green

ITEM	Item no.: 0512/02B fine crystal machine-made	Item no.: 0512/02R fine crystal machine-made	Item no.: 0512/02Y fine crystal machine-made	Item no.: 0512/02G fine crystal machine-made
	Height/glass: 98 mm	Height/glass: 98 mm	Height/glass: 98 mm	Height/glass: 98 mm
	Capacity/glass: 295 ccm	Capacity/glass: 295 ccm	Capacity/glass: 295 ccm	Capacity/glass: 295 ccm
	Design: 2019	Design: 2019	Design: 2019	Design: 2019
<b>PACKAGING</b>	Pieces/Bill unit: 1	Pieces/Bill unit: 1	Pieces/Bill unit: 1	Pieces/Bill unit: 1
<b>TYPE AND QUANTITY</b>	Bill units/MP: 12	Bill units/MP: 12	Bill units/MP: 12	Bill units/MP: 12
<b>MASTERPACK</b>	Length: 398 mm	Length: 398 mm	Length: 398 mm	Length: 398 mm
<b>DIMENSIONS</b>	Width: 296 mm	Width: 296 mm	Width: 296 mm	Width: 296 mm
	Height: 133 mm	Height: 133 mm	Height: 133 mm	Height: 133 mm
	Weight: 4102 gr	Weight: 4102 gr	Weight: 4102 gr	Weight: 4102 gr
<b>EURO PALLET</b>	Bill units/pallet: 1344	Bill units/pallet: 1344	Bill units/pallet: 1344	Bill units/pallet: 1344
	Bill units/layer: 96	Bill units/layer: 96	Bill units/layer: 96	Bill units/layer: 96
	Layers/pallet: 14	Layers/pallet: 14	Layers/pallet: 14	Layers/pallet: 14
<b>CONTAINER PALLET</b>	Bill units/pallet: 1680	Bill units/pallet: 1680	Bill units/pallet: 1680	Bill units/pallet: 1680
<b>HIGH CUBE</b>	Bill units/layer: 120	Bill units/layer: 120	Bill units/layer: 120	Bill units/layer: 120
	Layers/pallet: 14	Layers/pallet: 14	Layers/pallet: 14	Layers/pallet: 14
<b>EAN</b>				
<b>BILL UNIT</b>	9 006206 530083	9 006206 530090	9 006206 530106	9 006206 530113

**EXCLUDED FROM PROMOTIONS**



Highball



Double Old Fashioned



Single Old Fashioned

ITEM	Item no.: 0419/04 <b>fine crystal machine-made</b>	Item no.: 0419/02 <b>fine crystal machine-made</b>	Item no.: 0419/01 <b>fine crystal machine-made</b>
	Height/glass: 146 mm	Height/glass: 94 mm	Height/glass: 93 mm
	Capacity/glass: 350 ccm	Capacity/glass: 370 ccm	Capacity/glass: 290 ccm
	Design: 2014	Design: 2014	Design: 2014
<b>PACKAGING</b>	Pieces/Bill unit: 1	Pieces/Bill unit: 1	Pieces/Bill unit: 1
<b>TYPE AND QUANTITY</b>	Bill units/MP: 12	Bill units/MP: 12	Bill units/MP: 12
<b>MASTERPACK</b>	Length: 308 mm	Length: 365 mm	Length: 332 mm
<b>DIMENSIONS</b>	Width: 233 mm	Width: 276 mm	Width: 252 mm
	Height: 164 mm	Height: 111 mm	Height: 108 mm
	Weight: 4515 gr	Weight: 3986 gr	Weight: 3226 gr
<b>EURO PALLET</b>	Bill units/pallet: 1296	Bill units/pallet: 960	Bill units/pallet: 1920
	Bill units/layer: 144	Bill units/layer: 96	Bill units/layer: 120
	Layers/pallet: 9	Layers/pallet: 10	Layers/pallet: 16
<b>CONTAINER PALLET</b>	Bill units/pallet: 1536	Bill units/pallet: 1716	Bill units/pallet: 2184
<b>HIGH CUBE</b>	Bill units/layer: 192	Bill units/layer: 132	Bill units/layer: 168
	Layers/pallet: 8	Layers/pallet: 13	Layers/pallet: 13
<b>EAN BILL UNIT</b>	 9 006206 522842	 9 006206 522828	 9 006206 522811



Cabernet/Merlot



Pinot Noir



Riesling/Sauvignon/Champagne Glass

ITEM	Item no.: fine crystal machine-made	0789/0	Item no.: fine crystal machine-made	0789/07	Item no.: fine crystal machine-made	0789/15
	Height/glass:	121 mm	Height/glass:	121 mm	Height/glass:	109 mm
	Capacity/glass:	675 ccm	Capacity/glass:	630 ccm	Capacity/glass:	440 ccm
	Design:	2021	Design:	2021	Design:	2021
<b>PACKAGING</b>	Pieces/Bill unit:	1	Pieces/Bill unit:	1	Pieces/Bill unit:	1
<b>TYPE AND QUANTITY</b>	Bill units/MP:	12	Bill units/MP:	12	Bill units/MP:	12
<b>MASTERPACK</b>	Length:	421 mm	Length:	309 mm	Length:	382 mm
<b>DIMENSIONS</b>	Width:	312 mm	Width:	204 mm	Width:	282 mm
	Height:	126 mm	Height:	123 mm	Height:	114 mm
	Weight:	1800 gr	Weight:	1800 gr	Weight:	1507 gr
<b>EURO PALLET</b>	Bill units/pallet:	1008	Bill units/pallet:	1008	Bill units/pallet:	1536
	Bill units/layer:	72	Bill units/layer:	72	Bill units/layer:	96
	Layers/pallet:	14	Layers/pallet:	14	Layers/pallet:	16
<b>CONTAINER PALLET</b>	Bill units/pallet:	1836	Bill units/pallet:	1836	Bill units/pallet:	2508
<b>HIGH CUBE</b>	Bill units/layer:	108	Bill units/layer:	108	Bill units/layer:	132
	Layers/pallet:	17	Layers/pallet:	17	Layers/pallet:	19
<b>EAN BILL UNIT</b>	 9 006206 322077		 9 006206 322091		 9 006206 322084	





Syrah/Shiraz



Cabernet/Merlot



Pinot Noir/Nebbiolo



Champagne Glass

<b>ITEM</b>	<b>Item no.:</b> 0412/30 <b>fine crystal machine-made</b>	<b>Item no.:</b> 0412/0 <b>fine crystal machine-made</b>	<b>Item no.:</b> 0412/07 <b>fine crystal machine-made</b>	<b>Item no.:</b> 0412/28 <b>fine crystal machine-made</b>
	Height/glass: 132 mm Capacity/glass: 620 ccm Design: 2003	Height/glass: 121 mm Capacity/glass: 620 ccm Design: 2003	Height/glass: 110 mm Capacity/glass: 690 ccm Design: 2003	Height/glass: 122 mm Capacity/glass: 264 ccm Design: 2014
<b>PACKAGING</b>	Pieces/Bill unit: 1	Pieces/Bill unit: 1	Pieces/Bill unit: 1	Pieces/Bill unit: 1
<b>TYPE AND QUANTITY</b>	Bill units/MP: 12	Bill units/MP: 12	Bill units/MP: 12	Bill units/MP: 12
<b>MASTERPACK</b>	Length: 404 mm	Length: 404 mm	Length: 475 mm	Length: 267 mm
<b>DIMENSIONS</b>	Width: 308 mm	Width: 308 mm	Width: 354 mm	Width: 202 mm
	Height: 151 mm	Height: 140 mm	Height: 133 mm	Height: 135 mm
	Weight: 1787 gr	Weight: 1770 gr	Weight: 1356 gr	Weight: 1322 gr
<b>EURO PALLET</b>	Bill units/pallet: 864	Bill units/pallet: 936	Bill units/pallet: 672	Bill units/pallet: 2520
	Bill units/layer: 72	Bill units/layer: 72	Bill units/layer: 48	Bill units/layer: 180
	Layers/pallet: 12	Layers/pallet: 13	Layers/pallet: 14	Layers/pallet: 14
<b>CONTAINER PALLET</b>	Bill units/pallet: 1620	Bill units/pallet: 1728	Bill units/pallet: 1428	Bill units/pallet: 4896
<b>HIGH CUBE</b>	Bill units/layer: 108	Bill units/layer: 108	Bill units/layer: 84	Bill units/layer: 288
	Layers/pallet: 15	Layers/pallet: 16	Layers/pallet: 17	Layers/pallet: 17
<b>EAN BILL UNIT</b>	 9 006206 512225	 9 006206 512232	 9 006206 512249	 9 006206 522354



Riesling/Sauvignon Blanc







Viognier/Chardonnay



Oaked Chardonnay

Spirits/Fortified Wines/  
Cask Aged Brandies

ITEM	Item no.: fine crystal machine-made	0412/15	Item no.: fine crystal machine-made	0412/05	Item no.: fine crystal machine-made	0412/97	Item no.: fine crystal machine-made	0412/60
	Height/glass:	108 mm	Height/glass:	96 mm	Height/glass:	94 mm	Height/glass:	90 mm
	Capacity/glass:	375 ccm	Capacity/glass:	335 ccm	Capacity/glass:	580 ccm	Capacity/glass:	235 ccm
	Design:	2003	Design:	2003	Design:	2003	Design:	2004
<b>PACKAGING</b>	Pieces/Bill unit:	1	Pieces/Bill unit:	1	Pieces/Bill unit:	1	Pieces/Bill unit:	1
<b>TYPE AND QUANTITY</b>	Bill units/MP:	12	Bill units/MP:	12	Bill units/MP:	12	Bill units/MP:	12
<b>MASTERPACK</b>	Length:	343 mm	Length:	343 mm	Length:	475 mm	Length:	300 mm
<b>DIMENSIONS</b>	Width:	254 mm	Width:	254 mm	Width:	354 mm	Width:	230 mm
	Height:	111 mm	Height:	111 mm	Height:	133 mm	Height:	108 mm
	Weight:	1492 gr	Weight:	1444 gr	Weight:	1656 gr	Weight:	1299 gr
<b>EURO PALLET</b>	Bill units/pallet:	1920	Bill units/pallet:	1920	Bill units/pallet:	672	Bill units/pallet:	2652
	Bill units/layer:	120	Bill units/layer:	120	Bill units/layer:	48	Bill units/layer:	156
	Layers/pallet:	16	Layers/pallet:	16	Layers/pallet:	14	Layers/pallet:	17
<b>CONTAINER PALLET</b>	Bill units/pallet:	3360	Bill units/pallet:	3360	Bill units/pallet:	1428	Bill units/pallet:	4536
<b>HIGH CUBE</b>	Bill units/layer:	168	Bill units/layer:	168	Bill units/layer:	84	Bill units/layer:	216
	Layers/pallet:	20	Layers/pallet:	20	Layers/pallet:	17	Layers/pallet:	21
<b>EAN</b>	 9 006206 512270		 9 006206 512263		 9 006206 512256		 9 006206 512591	
<b>BILL UNIT</b>								





New World Pinot Noir

<b>ITEM</b>	<b>Item no.:</b> 0412/67 <b>fine crystal</b> <b>machine-made</b>
	Height/glass: 124 mm Capacity/glass: 760 ccm Design: 2014
<b>PACKAGING</b>	Pieces/Bill unit: 1
<b>TYPE AND QUANTITY</b>	Bill units/MP: 12
<b>MASTERPACK</b>	Length: 475 mm
<b>DIMENSIONS</b>	Width: 354 mm Height: 133 mm Weight: 1932 gr
<b>EURO PALLET</b>	Bill units/pallet: 672 Bill units/layer: 48 Layers/pallet: 14
<b>CONTAINER PALLET</b>	Bill units/pallet: 1428
<b>HIGH CUBE</b>	Bill units/layer: 84 Layers/pallet: 17
<b>EAN</b> <b>BILL UNIT</b>	 9 006206 522583





Viognier/Chardonnay  
Dawn-Red



Viognier/Chardonnay  
Spring-Green



Viognier/Chardonnay  
Easter-Yellow



Viognier/Chardonnay  
Baby-Blue

ITEM	Item no.: 0412/05r <b>fine crystal machine-made</b>	Item no.: 0412/05g <b>fine crystal machine-made</b>	Item no.: 0412/05y <b>fine crystal machine-made</b>	Item no.: 0412/05b <b>fine crystal machine-made</b>
	Height/glass: 96 mm	Height/glass: 96 mm	Height/glass: 96 mm	Height/glass: 96 mm
	Capacity/glass: 320 ccm	Capacity/glass: 320 ccm	Capacity/glass: 320 ccm	Capacity/glass: 320 ccm
	Design: 2014	Design: 2014	Design: 2014	Design: 2014
<b>PACKAGING</b>	Pieces/Bill unit: 1	Pieces/Bill unit: 1	Pieces/Bill unit: 1	Pieces/Bill unit: 1
<b>TYPE AND QUANTITY</b>	Bill units/MP: 12	Bill units/MP: 12	Bill units/MP: 12	Bill units/MP: 12
<b>MASTERPACK</b>	Length: 340 mm	Length: 340 mm	Length: 340 mm	Length: 340 mm
<b>DIMENSIONS</b>	Width: 260 mm	Width: 260 mm	Width: 260 mm	Width: 260 mm
	Height: 115 mm	Height: 115 mm	Height: 115 mm	Height: 115 mm
	Weight: 1457 gr	Weight: 1457 gr	Weight: 1457 gr	Weight: 1457 gr
<b>EURO PALLET</b>	Bill units/pallet: 1920	Bill units/pallet: 1920	Bill units/pallet: 1920	Bill units/pallet: 1920
	Bill units/layer: 120	Bill units/layer: 120	Bill units/layer: 120	Bill units/layer: 120
	Layers/pallet: 16	Layers/pallet: 16	Layers/pallet: 16	Layers/pallet: 16
<b>CONTAINER PALLET</b>	Bill units/pallet: 3360	Bill units/pallet: 3360	Bill units/pallet: 3360	Bill units/pallet: 3360
<b>HIGH CUBE</b>	Bill units/layer: 168	Bill units/layer: 168	Bill units/layer: 168	Bill units/layer: 168
	Layers/pallet: 20	Layers/pallet: 20	Layers/pallet: 20	Layers/pallet: 20
<b>EAN BILL UNIT</b>	 9 006206 523498	 9 006206 523474	 9 006206 523481	 9 006206 523504

**EXCLUDED FROM PROMOTIONS**



Viognier/Chardonnay  
Violet



Viognier/Chardonnay  
Cinnabar-Red



Viognier/Chardonnay  
Orange



Viognier/Chardonnay  
Azure-Blue

<b>ITEM</b>	<b>Item no.:</b> 0412/05v <b>fine crystal machine-made</b>	<b>Item no.:</b> 0412/05c <b>fine crystal machine-made</b>	<b>Item no.:</b> 0412/05o <b>fine crystal machine-made</b>	<b>Item no.:</b> 0412/05a <b>fine crystal machine-made</b>
	Height/glass: 96 mm Capacity/glass: 320 ccm Design: 2017	Height/glass: 96 mm Capacity/glass: 320 ccm Design: 2017	Height/glass: 96 mm Capacity/glass: 320 ccm Design: 2017	Height/glass: 96 mm Capacity/glass: 320 ccm Design: 2017
<b>PACKAGING</b>	Pieces/Bill unit: 1	Pieces/Bill unit: 1	Pieces/Bill unit: 1	Pieces/Bill unit: 1
<b>TYPE AND QUANTITY</b>	Bill units/MP: 12	Bill units/MP: 12	Bill units/MP: 12	Bill units/MP: 12
<b>MASTERPACK</b>	Length: 340 mm	Length: 340 mm	Length: 340 mm	Length: 340 mm
<b>DIMENSIONS</b>	Width: 260 mm	Width: 260 mm	Width: 260 mm	Width: 260 mm
	Height: 115 mm	Height: 115 mm	Height: 115 mm	Height: 115 mm
	Weight: 1457 gr	Weight: 1457 gr	Weight: 1457 gr	Weight: 1457 gr
<b>EURO PALLET</b>	Bill units/pallet: 1920	Bill units/pallet: 1920	Bill units/pallet: 1920	Bill units/pallet: 1920
	Bill units/layer: 120	Bill units/layer: 120	Bill units/layer: 120	Bill units/layer: 120
	Layers/pallet: 16	Layers/pallet: 16	Layers/pallet: 16	Layers/pallet: 16
<b>CONTAINER PALLET</b>	Bill units/pallet: 3360	Bill units/pallet: 3360	Bill units/pallet: 3360	Bill units/pallet: 3360
<b>HIGH CUBE</b>	Bill units/layer: 168	Bill units/layer: 168	Bill units/layer: 168	Bill units/layer: 168
	Layers/pallet: 20	Layers/pallet: 20	Layers/pallet: 20	Layers/pallet: 20
<b>EAN BILL UNIT</b>	 9 006206 525942	 9 006206 525928	 9 006206 525935	 9 006206 525911



**EXCLUDED FROM PROMOTIONS**



Red Wine



White Wine

<b>ITEM</b>	<b>Item no.:</b> 0413/30 <b>fine crystal machine-made</b>	<b>Item no.:</b> 0413/33 <b>fine crystal machine-made</b>
	Height/glass: 120 mm	Height/glass: 103 mm
	Capacity/glass: 580 ccm	Capacity/glass: 380 ccm
	Design: 2010	Design: 2010
<b>PACKAGING</b>	Pieces/Bill unit: 1	Pieces/Bill unit: 1
<b>TYPE AND QUANTITY</b>	Bill units/MP: 12	Bill units/MP: 12
<b>MASTERPACK</b>	Length: 394 mm	Length: 343 mm
<b>DIMENSIONS</b>	Width: 296 mm	Width: 254 mm
	Height: 140 mm	Height: 111 mm
	Weight: 1850 gr	Weight: 1492 gr
<b>EURO PALLET</b>	Bill units/pallet: 1248	Bill units/pallet: 1920
	Bill units/layer: 96	Bill units/layer: 120
	Layers/pallet: 13	Layers/pallet: 16
<b>CONTAINER PALLET</b>	Bill units/pallet: 1920	Bill units/pallet: 3360
<b>HIGH CUBE</b>	Bill units/layer: 120	Bill units/layer: 168
	Layers/pallet: 16	Layers/pallet: 20
<b>EAN BILL UNIT</b>	 9 006206 516100	 9 006206 516117



RIEDEL Restaurant  
Champagne Wine Glass  
+ Line Measure 0,1L

RIEDEL Restaurant  
Champagne Glass  
+ Line Measure 0,1L

RIEDEL Restaurant  
Riesling  
+ Line Measure 0,1L + 0,2L

Extreme Restaurant  
Shiraz  
+ 0,1L Star + 0,2L Line Measure

ITEM	Item no.: fine crystal machine-made	0446/58-1	Item no.: fine crystal machine-made	0446/48-1	Item no.: fine crystal machine-made	0446/15-1	Item no.: fine crystal machine-made	0454/32-1
	Height/glass:	221 mm	Height/glass:	217 mm	Height/glass:	214 mm	Height/glass:	244 mm
	Capacity/glass:	480 ccm	Capacity/glass:	260 ccm	Capacity/glass:	370 ccm	Capacity/glass:	709 ccm
	Design:	2018	Design:	2016	Design:	2016	Design:	2019
<b>PACKAGING</b>	Pieces/Bill unit:	1	Pieces/Bill unit:	1	Pieces/Bill unit:	1	Pieces/Bill unit:	1
<b>TYPE AND QUANTITY</b>	Bill units/MP:	12	Bill units/MP:	12	Bill units/MP:	12	Bill units/MP:	12
<b>MASTERPACK</b>	Length:	367 mm	Length:	295 mm	Length:	368 mm	Length:	443 mm
<b>DIMENSIONS</b>	Width:	271 mm	Width:	219 mm	Width:	275 mm	Width:	330 mm
	Height:	230 mm	Height:	232 mm	Height:	244 mm	Height:	261 mm
	Weight:	2244 gr	Weight:	1865 gr	Weight:	2130 gr	Weight:	2822 gr
<b>EURO PALLET</b>	Bill units/pallet:	768	Bill units/pallet:	1248	Bill units/pallet:	672	Bill units/pallet:	420
	Bill units/layer:	96	Bill units/layer:	156	Bill units/layer:	96	Bill units/layer:	60
	Layers/pallet:	8	Layers/pallet:	8	Layers/pallet:	7	Layers/pallet:	7
<b>CONTAINER PALLET</b>	Bill units/pallet:	1320	Bill units/pallet:	2160	Bill units/pallet:	1188	Bill units/pallet:	768
<b>HIGH CUBE</b>	Bill units/layer:	132	Bill units/layer:	216	Bill units/layer:	132	Bill units/layer:	96
	Layers/pallet:	10	Layers/pallet:	10	Layers/pallet:	9	Layers/pallet:	8
<b>EAN BILL UNIT</b>	 9 006206 527342		 9 006206 524464		 9 006206 524440		 9 006206 529216	



Extreme Restaurant  
Riesling/Sauvignon Blanc  
+ 0,1L Star + 0,2L Line Measure

Extreme Restaurant  
Rosé Champagne Glass/Rosé Wine  
+ Line Measure 0,1L

Degustazione  
Red Wine  
+ Line Measure 0,1L + 0,2L

Degustazione  
Champagne Flute  
+ Line Measure 0,1L

ITEM	Item no.: fine crystal machine-made	0454/05-1	Item no.: fine crystal machine-made	0454/55-1	Item no.: fine crystal machine-made	0489/0-1	Item no.: fine crystal machine-made	0489/48-1
	Height/glass:	240 mm	Height/glass:	230 mm	Height/glass:	224 mm	Height/glass:	224 mm
	Capacity/glass:	490 ccm	Capacity/glass:	322 ccm	Capacity/glass:	560 ccm	Capacity/glass:	212 ccm
	Design:	2019	Design:	2019	Design:	2010	Design:	2015
<b>PACKAGING</b>	Pieces/Bill unit:	1	Pieces/Bill unit:	1	Pieces/Bill unit:	1	Pieces/Bill unit:	1
<b>TYPE AND QUANTITY</b>	Bill units/MP:	12	Bill units/MP:	12	Bill units/MP:	12	Bill units/MP:	12
<b>MASTERPACK</b>	Length:	371 mm	Length:	371 mm	Length:	377 mm	Length:	337 mm
<b>DIMENSIONS</b>	Width:	276 mm	Width:	276 mm	Width:	282 mm	Width:	251 mm
	Height:	254 mm	Height:	254 mm	Height:	242 mm	Height:	238 mm
	Weight:	2458 gr	Weight:	2269 gr	Weight:	2508 gr	Weight:	1990 gr
<b>EURO PALLET</b>	Bill units/pallet:	672	Bill units/pallet:	672	Bill units/pallet:	672	Bill units/pallet:	960
	Bill units/layer:	96	Bill units/layer:	96	Bill units/layer:	96	Bill units/layer:	120
	Layers/pallet:	7	Layers/pallet:	7	Layers/pallet:	7	Layers/pallet:	8
<b>CONTAINER PALLET</b>	Bill units/pallet:	1188	Bill units/pallet:	1188	Bill units/pallet:	1188	Bill units/pallet:	1512
<b>HIGH CUBE</b>	Bill units/layer:	132	Bill units/layer:	132	Bill units/layer:	132	Bill units/layer:	168
	Layers/pallet:	9	Layers/pallet:	9	Layers/pallet:	9	Layers/pallet:	9
<b>EAN</b>								
<b>BILL UNIT</b>	9 006206 529193		9 006206 529230		9 006206 524426		9 006206 524518	

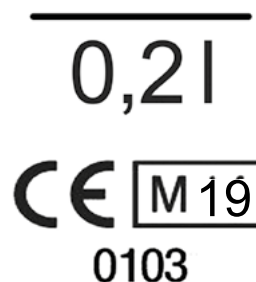



RIEDEL Restaurant  
Champagne Wine Glass  
+ Pour Aid CCM



RIEDEL Restaurant  
Champagne Glass  
+ Pour Aid CCM



RIEDEL Restaurant  
Cabernet/Merlot  
+ Pour Aid CCM



RIEDEL Restaurant  
Old World Pinot Noir  
+ Pour Aid CCM

ITEM	Item no.: fine crystal machine-made	0446/58-M	Item no.: fine crystal machine-made	0446/48-M	Item no.: fine crystal machine-made	0446/0-M	Item no.: fine crystal machine-made	0446/07-M
	Height/glass:	221 mm	Height/glass:	217 mm	Height/glass:	217 mm	Height/glass:	215 mm
	Capacity/glass:	480 ccm	Capacity/glass:	260 ccm	Capacity/glass:	610 ccm	Capacity/glass:	700 ccm
	Design:	2018	Design:	2016	Design:	2016	Design:	2016
<b>PACKAGING</b>	Pieces/Bill unit:	1	Pieces/Bill unit:	1	Pieces/Bill unit:	1	Pieces/Bill unit:	1
<b>TYPE AND QUANTITY</b>	Bill units/MP:	12	Bill units/MP:	12	Bill units/MP:	12	Bill units/MP:	12
<b>MASTERPACK</b>	Length:	367 mm	Length:	295 mm	Length:	444 mm	Length:	444 mm
<b>DIMENSIONS</b>	Width:	271 mm	Width:	219 mm	Width:	332 mm	Width:	332 mm
	Height:	230 mm	Height:	232 mm	Height:	243 mm	Height:	243 mm
	Weight:	2244 gr	Weight:	1865 gr	Weight:	2642 gr	Weight:	2158 gr
<b>EURO PALLET</b>	Bill units/pallet:	768	Bill units/pallet:	1248	Bill units/pallet:	420	Bill units/pallet:	420
	Bill units/layer:	96	Bill units/layer:	156	Bill units/layer:	60	Bill units/layer:	60
	Layers/pallet:	8	Layers/pallet:	8	Layers/pallet:	7	Layers/pallet:	7
<b>CONTAINER PALLET</b>	Bill units/pallet:	1320	Bill units/pallet:	2160	Bill units/pallet:	864	Bill units/pallet:	864
<b>HIGH CUBE</b>	Bill units/layer:	132	Bill units/layer:	216	Bill units/layer:	96	Bill units/layer:	96
	Layers/pallet:	10	Layers/pallet:	10	Layers/pallet:	9	Layers/pallet:	9
<b>EAN</b>								
<b>BILL UNIT</b>	9 006206 527496		9 006206 524914		9 006206 524792		9 006206 524839	



RIEDEL Restaurant  
Riesling  
+ Pour Aid CCM

<b>ITEM</b>	<b>Item no.:</b> 0446/15-M <b>fine crystal</b> <b>machine-made</b>
	Height/glass: 214 mm Capacity/glass: 370 ccm Design: 2016
<b>PACKAGING</b>	Pieces/Bill unit: 1
<b>TYPE AND QUANTITY</b>	Bill units/MP: 12
<b>MASTERPACK</b>	Length: 368 mm
<b>DIMENSIONS</b>	Width: 275 mm Height: 244 mm Weight: 2130 gr
<b>EURO PALLET</b>	Bill units/pallet: 672 Bill units/layer: 96 Layers/pallet: 7
<b>CONTAINER PALLET</b>	Bill units/pallet: 1188
<b>HIGH CUBE</b>	Bill units/layer: 132 Layers/pallet: 9
<b>EAN</b> <b>BILL UNIT</b>	 9 006206 524853

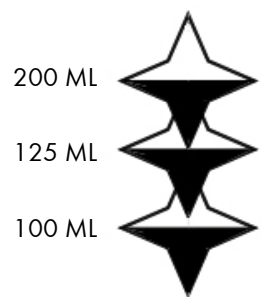

Pour aid CCM



RIEDEL Microfiber Polishing Cloths



RIEDEL Microfiber Polishing Cloth

ITEM	Item no.:	5010/07	Item no.:	0010/07
	-		-	
	-		-	
	Height:	-	Height:	-
	Capacity/glass:	-	Capacity/glass:	-
	Design:	2010	Design:	2006
<b>PACKAGING</b>	Pieces/Bill unit:	20	Pieces/Bill unit:	1
<b>TYPE AND QUANTITY</b>	Bill units/MP:	1	Bill units/MP:	-
<b>MASTERPACK</b>	Length:	285 mm	Length:	-
<b>DIMENSIONS</b>	Width:	186 mm	Width:	-
	Height:	6 mm	Height:	-
	Weight:	2206 gr	Weight:	85 gr
<b>EURO PALLET</b>	Bill units/pallet:	2600	Bill units/pallet:	4320
	Bill units/layer:	260	Bill units/layer:	720
	Layers/pallet:	10	Layers/pallet:	6
<b>CONTAINER PALLET</b>	Bill units/pallet:	4400	Bill units/pallet:	9600
<b>HIGH CUBE</b>	Bill units/layer:	440	Bill units/layer:	1200
	Layers/pallet:	10	Layers/pallet:	8
<b>EAN</b>	 9 006206 212798		 9 006206 212781	
<b>BILL UNIT</b>				







Amadeo Double Magnum Decanter



Horn Decanter

<b>ITEM</b>	<b>Item no.:</b>	1756/80	<b>Item no.:</b>	2014/02
	<b>fine crystal</b>		<b>fine crystal</b>	
	<b>handmade</b>		<b>handmade</b>	
	Height/glass:	680 mm	Height/glass:	370 mm
	Capacity/glass:	3000 ccm	Capacity/glass:	2500 ccm
	Design:	2014	Design:	2014
<b>PACKAGING</b>	Pieces/Bill unit:	1	Pieces/Bill unit:	1
<b>TYPE AND QUANTITY</b>	Bill units/MP:	1	Bill units/MP:	1
<b>BILL UNIT</b>	Length:	412 mm	Length:	303 mm
<b>DIMENSIONS</b>	Width:	207 mm	Width:	183 mm
	Height:	755 mm	Height:	458 mm
	Weight:	3000 gr	Weight:	1207 gr
<b>MASTERPACK</b>	Length:	422 mm	Length:	314 mm
<b>DIMENSIONS</b>	Width:	218 mm	Width:	194 mm
	Height:	766 mm	Height:	464 mm
	Weight:	3500 gr	Weight:	1383 gr
<b>EURO PALLET</b>	Bill units/pallet:	20	Bill units/pallet:	56
	Bill units/layer:	5	Bill units/layer:	14
	Layers/pallet:	4	Layers/pallet:	4
<b>CONTAINER PALLET</b>	Bill units/pallet:	36	Bill units/pallet:	100
<b>HIGH CUBE</b>	Bill units/layer:	12	Bill units/layer:	20
	Layers/pallet:	3	Layers/pallet:	5
<b>EAN</b>				
<b>BILL UNIT</b>	9 006206 214051		9 006206 311743	

**R.Q. (RESTAURANT QUALITY) OF  
HANDMADE DECANTERS ONLY UPON AVAILABILITY.**





Black Tie Decanter



Decanter Tyrol



Horse Decanter

<b>ITEM</b>	<b>Item no.:</b> 4100/23 <b>fine crystal handmade</b>	<b>Item no.:</b> 1405/13 <b>fine crystal handmade</b>	<b>Item no.:</b> 4101/13 <b>fine crystal handmade</b>
	Height/glass: 420 mm Capacity/glass: 1955 ccm Design: 2009	Height/glass: 192 mm Capacity/glass: 1870 ccm Design: 2007	Height/glass: 600 mm Capacity/glass: 1766 ccm Design: 2014
<b>PACKAGING TYPE AND QUANTITY</b>	Pieces/Bill unit: 1 Bill units/MP: 1	Pieces/Bill unit: 1 Bill units/MP: 1	Pieces/Bill unit: 1 Bill units/MP: 1
<b>BILL UNIT DIMENSIONS</b>	Length: 279 mm Width: 275 mm Height: 551 mm Weight: 1246 gr	Length: 279 mm Width: 275 mm Height: 551 mm Weight: 1746 gr	Length: 275 mm Width: 225 mm Height: 632 mm Weight: 1532 gr
<b>MASTERPACK DIMENSIONS</b>	Length: 290 mm Width: 281 mm Height: 556 mm Weight: 1484 gr	Length: 290 mm Width: 281 mm Height: 556 mm Weight: 1984 gr	Length: 286 mm Width: 234 mm Height: 634 mm Weight: 1780 gr
<b>EURO PALLET</b>	Bill units/pallet: 24 Bill units/layer: 4 Layers/pallet: 6	Bill units/pallet: 24 Bill units/layer: 4 Layers/pallet: 6	Bill units/pallet: 30 Bill units/layer: 5 Layers/pallet: 6
<b>CONTAINER PALLET HIGH CUBE</b>	Bill units/pallet: 48 Bill units/layer: 6 Layers/pallet: 8	Bill units/pallet: 48 Bill units/layer: 6 Layers/pallet: 8	Bill units/pallet: 54 Bill units/layer: 6 Layers/pallet: 9
<b>EAN BILL UNIT</b>	 9 006206 311439	 9 006206 311354	 9 006206 311798

**CAUTION:** the indented design feature of this decanter must not be used as a handle. Do not insert your hand or any item into the indented area.  
Cleaning beads should not be used.  
Carefully hand wash only.





Black Tie Face To Face Decanter



Mamba Decanter



Eve Decanter

ITEM	Item no.: fine crystal handmade	4100/13	Item no.: fine crystal handmade	1950/19	Item no.: fine crystal handmade	1950/09
	Height/glass:	600 mm	Height/glass:	325 mm	Height/glass:	505 mm
	Capacity/glass:	1766 ccm	Capacity/glass:	1500 ccm	Capacity/glass:	1370 ccm
	Design:	2009	Design:	2011	Design:	2009
<b>PACKAGING</b>	Pieces/Bill unit:	1	Pieces/Bill unit:	1	Pieces/Bill unit:	1
<b>TYPE AND QUANTITY</b>	Bill units/MP:	1	Bill units/MP:	1	Bill units/MP:	1
<b>BILL UNIT</b>	Length:	275 mm	Length:	420 mm	Length:	279 mm
<b>DIMENSIONS</b>	Width:	225 mm	Width:	267 mm	Width:	275 mm
	Height:	632 mm	Height:	435 mm	Height:	551 mm
	Weight:	1532 gr	Weight:	1660 gr	Weight:	1346 gr
<b>MASTERPACK</b>	Length:	286 mm	Length:	425 mm	Length:	290 mm
<b>DIMENSIONS</b>	Width:	234 mm	Width:	273 mm	Width:	281 mm
	Height:	634 mm	Height:	445 mm	Height:	556 mm
	Weight:	1780 gr	Weight:	2020 gr	Weight:	1584 gr
<b>EURO PALLET</b>	Bill units/pallet:	30	Bill units/pallet:	24	Bill units/pallet:	24
	Bill units/layer:	5	Bill units/layer:	6	Bill units/layer:	4
	Layers/pallet:	6	Layers/pallet:	4	Layers/pallet:	6
<b>CONTAINER PALLET</b>	Bill units/pallet:	54	Bill units/pallet:	45	Bill units/pallet:	48
<b>HIGH CUBE</b>	Bill units/layer:	6	Bill units/layer:	9	Bill units/layer:	6
	Layers/pallet:	9	Layers/pallet:	5	Layers/pallet:	8
<b>EAN</b>	 9 006206 311446		 9 006206 311484		 9 006206 311422	
<b>BILL UNIT</b>						

**CAUTION:** the indented design feature of this decanter must not be used as a handle. Do not insert your hand or any item into the indented area.  
Cleaning beads should not be used.  
Carefully hand wash only.



Boa Decanter







Amadeo Decanter  
Blue



Amadeo Decanter  
Menta



Amadeo Decanter  
Rosa

ITEM	Item no.: fine crystal handmade	2013/01	Item no.: fine crystal handmade	1756/13B	Item no.: fine crystal handmade	1756/13-M	Item no.: fine crystal handmade	1756/13-R
	Height/glass:	350 mm	Height/glass:	350 mm	Height/glass:	350 mm	Height/glass:	350 mm
	Capacity/glass:	1957 ccm	Capacity/glass:	1500 ccm	Capacity/glass:	1500 ccm	Capacity/glass:	1500 ccm
	Design:	2013	Design:	2022	Design:	2019	Design:	2019
<b>PACKAGING</b>	Pieces/Bill unit:	1	Pieces/Bill unit:	1	Pieces/Bill unit:	1	Pieces/Bill unit:	1
<b>TYPE AND QUANTITY</b>	Bill units/MP:	1	Bill units/MP:	1	Bill units/MP:	1	Bill units/MP:	1
<b>BILL UNIT</b>	Length:	279 mm	Length:	303 mm	Length:	303 mm	Length:	303 mm
<b>DIMENSIONS</b>	Width:	275 mm	Width:	183 mm	Width:	183 mm	Width:	183 mm
	Height:	551 mm	Height:	458 mm	Height:	458 mm	Height:	458 mm
	Weight:	1316 gr	Weight:	1097 gr	Weight:	1097 gr	Weight:	1097 gr
<b>MASTERPACK</b>	Length:	290 mm	Length:	314 mm	Length:	314 mm	Length:	314 mm
<b>DIMENSIONS</b>	Width:	281 mm	Width:	194 mm	Width:	194 mm	Width:	194 mm
	Height:	556 mm	Height:	464 mm	Height:	464 mm	Height:	464 mm
	Weight:	1554 gr	Weight:	1273 gr	Weight:	1273 gr	Weight:	1273 gr
<b>EURO PALLET</b>	Bill units/pallet:	24	Bill units/pallet:	56	Bill units/pallet:	56	Bill units/pallet:	56
	Bill units/layer:	4	Bill units/layer:	14	Bill units/layer:	14	Bill units/layer:	14
	Layers/pallet:	6	Layers/pallet:	4	Layers/pallet:	4	Layers/pallet:	4
<b>CONTAINER PALLET</b>	Bill units/pallet:	48	Bill units/pallet:	100	Bill units/pallet:	100	Bill units/pallet:	100
<b>HIGH CUBE</b>	Bill units/layer:	6	Bill units/layer:	20	Bill units/layer:	20	Bill units/layer:	20
	Layers/pallet:	8	Layers/pallet:	5	Layers/pallet:	5	Layers/pallet:	5
<b>EAN</b>	 9 006206 213672		 9 006206 324040		 9 006206 313303		 9 006206 313327	
<b>BILL UNIT</b>								



Amadeo Decanter







Black Tie Amadeo Decanter



RIEDEL Winewings Decanter



Swan Decanter

ITEM	Item no.: fine crystal handmade	1756/13	Item no.: fine crystal handmade	4100/83	Item no.: fine crystal handmade	2007/0251	Item no.: fine crystal handmade	2007/02
	Height/glass:	350 mm	Height/glass:	350 mm	Height/glass:	600 mm	Height/glass:	600 mm
	Capacity/glass:	1500 ccm	Capacity/glass:	1500 ccm	Capacity/glass:	850 ccm	Capacity/glass:	1570 ccm
	Design:	2006	Design:	2009	Design:	2020	Design:	2008
<b>PACKAGING</b>	Pieces/Bill unit:	1	Pieces/Bill unit:	1	Pieces/Bill unit:	1	Pieces/Bill unit:	1
<b>TYPE AND QUANTITY</b>	Bill units/MP:	1	Bill units/MP:	1	Bill units/MP:	1	Bill units/MP:	1
<b>BILL UNIT</b>	Length:	303 mm	Length:	303 mm	Length:	275 mm	Length:	275 mm
<b>DIMENSIONS</b>	Width:	183 mm	Width:	183 mm	Width:	225 mm	Width:	225 mm
	Height:	458 mm	Height:	458 mm	Height:	632 mm	Height:	632 mm
	Weight:	1097 gr	Weight:	1067 gr	Weight:	1190 gr	Weight:	1162 gr
<b>MASTERPACK</b>	Length:	314 mm	Length:	314 mm	Length:	286 mm	Length:	286 mm
<b>DIMENSIONS</b>	Width:	194 mm	Width:	194 mm	Width:	234 mm	Width:	234 mm
	Height:	464 mm	Height:	464 mm	Height:	634 mm	Height:	634 mm
	Weight:	1273 gr	Weight:	1243 gr	Weight:	1438 gr	Weight:	1410 gr
<b>EURO PALLET</b>	Bill units/pallet:	56	Bill units/pallet:	56	Bill units/pallet:	30	Bill units/pallet:	30
	Bill units/layer:	14	Bill units/layer:	14	Bill units/layer:	5	Bill units/layer:	5
	Layers/pallet:	4	Layers/pallet:	4	Layers/pallet:	6	Layers/pallet:	6
<b>CONTAINER PALLET</b>	Bill units/pallet:	100	Bill units/pallet:	100	Bill units/pallet:	54	Bill units/pallet:	54
<b>HIGH CUBE</b>	Bill units/layer:	20	Bill units/layer:	20	Bill units/layer:	6	Bill units/layer:	6
	Layers/pallet:	5	Layers/pallet:	5	Layers/pallet:	9	Layers/pallet:	9
<b>EAN</b>	 9 006206 212736		 9 006206 311408		 9 006206 313754		 9 006206 311385	
<b>BILL UNIT</b>								



reddot design award





Amadeo Mini Decanter



Mamba Fatto A Mano Decanter



Amadeo Fatto A Mano Decanter

ITEM	Item no.: fine crystal handmade	1756/14	Item no.: fine crystal handmade	1950/00	Item no.: fine crystal handmade	1756/00
	Height/glass:	250 mm	Height/glass:	325 mm	Height/glass:	350 mm
	Capacity/glass:	750 ccm	Capacity/glass:	1500 ccm	Capacity/glass:	1500 ccm
	Design:	2019	Design:	2017	Design:	2017
<b>PACKAGING</b>	Pieces/Bill unit:	1	Pieces/Bill unit:	1	Pieces/Bill unit:	1
<b>TYPE AND QUANTITY</b>	Bill units/MP:	1	Bill units/MP:	1	Bill units/MP:	1
<b>BILL UNIT</b>	Length:	291 mm	Length:	420 mm	Length:	303 mm
<b>DIMENSIONS</b>	Width:	198 mm	Width:	267 mm	Width:	183 mm
	Height:	224 mm	Height:	435 mm	Height:	458 mm
	Weight:	552 gr	Weight:	1660 gr	Weight:	1097 gr
<b>MASTERPACK</b>	Length:	-	Length:	425 mm	Length:	314 mm
<b>DIMENSIONS</b>	Width:	-	Width:	273 mm	Width:	194 mm
	Height:	-	Height:	445 mm	Height:	464 mm
	Weight:	-	Weight:	2020 gr	Weight:	1273 gr
<b>EURO PALLET</b>	Bill units/pallet:	128	Bill units/pallet:	24	Bill units/pallet:	56
	Bill units/layer:	16	Bill units/layer:	6	Bill units/layer:	14
	Layers/pallet:	8	Layers/pallet:	4	Layers/pallet:	4
<b>CONTAINER PALLET</b>	Bill units/pallet:	224	Bill units/pallet:	45	Bill units/pallet:	100
<b>HIGH CUBE</b>	Bill units/layer:	28	Bill units/layer:	9	Bill units/layer:	20
	Layers/pallet:	8	Layers/pallet:	5	Layers/pallet:	5
<b>EAN</b>	 9 006206 312979		 9 006206 312788		 9 006206 312795	
<b>BILL UNIT</b>						



**Limited Editions:** TG reserves the right to offer glassware marked as "Limited Edition" in a certain amount and for a certain time period and under certain allocation criteria to Customer.





Amadeo Performance Decanter







Ayam Decanter



Ayam Decanter  
Black



Duck Decanter

ITEM	Item no.: fine crystal handmade	1756/19	Item no.: fine crystal handmade	2016/01	Item no.: fine crystal handmade	2016/02	Item no.: fine crystal handmade	1700/14
	Height/glass:	350 mm	Height/glass:	287 mm	Height/glass:	287 mm	Height/glass:	130 mm
	Capacity/glass:	1500 ccm	Capacity/glass:	1700 ccm	Capacity/glass:	1700 ccm	Capacity/glass:	900 ccm
	Design:	2019	Design:	2016	Design:	2016	Design:	1998
<b>PACKAGING</b>	Pieces/Bill unit:	1	Pieces/Bill unit:	1	Pieces/Bill unit:	1	Pieces/Bill unit:	1
<b>TYPE AND QUANTITY</b>	Bill units/MP:	1	Bill units/MP:	1	Bill units/MP:	1	Bill units/MP:	1
<b>BILL UNIT</b>	Length:	303 mm	Length:	303 mm	Length:	303 mm	Length:	303 mm
<b>DIMENSIONS</b>	Width:	183 mm	Width:	183 mm	Width:	183 mm	Width:	183 mm
	Height:	458 mm	Height:	458 mm	Height:	458 mm	Height:	458 mm
	Weight:	1097 gr	Weight:	1147 gr	Weight:	1147 gr	Weight:	1357 gr
<b>MASTERPACK</b>	Length:	314 mm	Length:	314 mm	Length:	314 mm	Length:	314 mm
<b>DIMENSIONS</b>	Width:	194 mm	Width:	194 mm	Width:	194 mm	Width:	194 mm
	Height:	464 mm	Height:	464 mm	Height:	464 mm	Height:	464 mm
	Weight:	1273 gr	Weight:	1323 gr	Weight:	1323 gr	Weight:	1533 gr
<b>EURO PALLET</b>	Bill units/pallet:	56	Bill units/pallet:	56	Bill units/pallet:	56	Bill units/pallet:	56
	Bill units/layer:	14	Bill units/layer:	14	Bill units/layer:	14	Bill units/layer:	14
	Layers/pallet:	4	Layers/pallet:	4	Layers/pallet:	4	Layers/pallet:	4
<b>CONTAINER PALLET</b>	Bill units/pallet:	100	Bill units/pallet:	100	Bill units/pallet:	100	Bill units/pallet:	100
<b>HIGH CUBE</b>	Bill units/layer:	20	Bill units/layer:	20	Bill units/layer:	20	Bill units/layer:	20
	Layers/pallet:	5	Layers/pallet:	5	Layers/pallet:	5	Layers/pallet:	5
<b>EAN</b>	 9 006206 313198		 9 006206 312412		 9 006206 312429		 9 006206 727216	
<b>BILL UNIT</b>								







RIEDEL Superleggero Decanter



Escargot Decanter



Cornetto Magnum Decanter

ITEM	Item no.: fine crystal handmade	1925/01	Item no.: fine crystal machine-made	2011/02	Item no.: fine crystal handmade	1977/26
	Height/glass:	410 mm	Height/glass:	150 mm	Height/glass:	425 mm
	Capacity/glass:	1585 ccm	Capacity/glass:	1400 ccm	Capacity/glass:	1850 ccm
	Design:	2015	Design:	2011	Design:	2003
<b>PACKAGING</b>	Pieces/Bill unit:	1	Pieces/Bill unit:	1	Pieces/Bill unit:	1
<b>TYPE AND QUANTITY</b>	Bill units/MP:	1	Bill units/MP:	1	Bill units/MP:	1
<b>BILL UNIT</b>	Length:	172 mm	Length:	303 mm	Length:	172 mm
<b>DIMENSIONS</b>	Width:	172 mm	Width:	183 mm	Width:	172 mm
	Height:	476 mm	Height:	458 mm	Height:	476 mm
	Weight:	960 gr	Weight:	1217 gr	Weight:	960 gr
<b>MASTERPACK</b>	Length:	177 mm	Length:	314 mm	Length:	177 mm
<b>DIMENSIONS</b>	Width:	177 mm	Width:	194 mm	Width:	177 mm
	Height:	477 mm	Height:	464 mm	Height:	477 mm
	Weight:	1091 gr	Weight:	1393 gr	Weight:	1091 gr
<b>EURO PALLET</b>	Bill units/pallet:	90	Bill units/pallet:	56	Bill units/pallet:	90
	Bill units/layer:	9	Bill units/layer:	14	Bill units/layer:	9
	Layers/pallet:	10	Layers/pallet:	4	Layers/pallet:	10
<b>CONTAINER PALLET</b>	Bill units/pallet:	182	Bill units/pallet:	100	Bill units/pallet:	182
<b>HIGH CUBE</b>	Bill units/layer:	14	Bill units/layer:	20	Bill units/layer:	14
	Layers/pallet:	13	Layers/pallet:	5	Layers/pallet:	13
<b>EAN</b>	 9 006206 312139		 9 006206 311491		 9 006206 311286	
<b>BILL UNIT</b>						







RIEDEL Cornetto Confetti Decanter  
**Red**

RIEDEL Cornetto Confetti Decanter  
**Blue**

RIEDEL Cornetto Confetti Decanter  
**Green**

RIEDEL Cornetto Confetti Decanter  
**Yellow**

ITEM	Item no.: 1977/13R <b>fine crystal handmade</b>	Item no.: 1977/13B <b>fine crystal handmade</b>	Item no.: 1977/13G <b>fine crystal handmade</b>	Item no.: 1977/13Y <b>fine crystal handmade</b>
	Height/glass: 325 mm	Height/glass: 325 mm	Height/glass: 325 mm	Height/glass: 325 mm
	Capacity/glass: 1200 ccm	Capacity/glass: 1200 ccm	Capacity/glass: 1200 ccm	Capacity/glass: 1200 ccm
	Design: 2020	Design: 2020	Design: 2020	Design: 2020
<b>PACKAGING</b>	Pieces/Bill unit: 1	Pieces/Bill unit: 1	Pieces/Bill unit: 1	Pieces/Bill unit: 1
<b>TYPE AND QUANTITY</b>	Bill units/MP: 1	Bill units/MP: 1	Bill units/MP: 1	Bill units/MP: 1
<b>BILL UNIT</b>	Length: 172 mm	Length: 172 mm	Length: 172 mm	Length: 172 mm
<b>DIMENSIONS</b>	Width: 172 mm	Width: 172 mm	Width: 172 mm	Width: 172 mm
	Height: 476 mm	Height: 476 mm	Height: 476 mm	Height: 476 mm
	Weight: 660 gr	Weight: 660 gr	Weight: 660 gr	Weight: 660 gr
<b>MASTERPACK</b>	Length: 177 mm	Length: 177 mm	Length: 177 mm	Length: 177 mm
<b>DIMENSIONS</b>	Width: 177 mm	Width: 177 mm	Width: 177 mm	Width: 177 mm
	Height: 477 mm	Height: 477 mm	Height: 477 mm	Height: 477 mm
	Weight: 791 gr	Weight: 791 gr	Weight: 791 gr	Weight: 791 gr
<b>EURO PALLET</b>	Bill units/pallet: 90	Bill units/pallet: 90	Bill units/pallet: 90	Bill units/pallet: 90
	Bill units/layer: 9	Bill units/layer: 9	Bill units/layer: 9	Bill units/layer: 9
	Layers/pallet: 10	Layers/pallet: 10	Layers/pallet: 10	Layers/pallet: 10
<b>CONTAINER PALLET</b>	Bill units/pallet: 182	Bill units/pallet: 182	Bill units/pallet: 182	Bill units/pallet: 182
<b>HIGH CUBE</b>	Bill units/layer: 14	Bill units/layer: 14	Bill units/layer: 14	Bill units/layer: 14
	Layers/pallet: 13	Layers/pallet: 13	Layers/pallet: 13	Layers/pallet: 13
<b>EAN BILL UNIT</b>	 9 006206 313693	 9 006206 313709	 9 006206 313723	 9 006206 313716



RIEDEL Cornetto Confetti Decanter  
Pink



Curly Decanter



Curly Decanter  
Pink



Curly Fatto A Mano Decanter

ITEM	Item no.: fine crystal handmade	1977/13DP	Item no.: fine crystal handmade	2011/04S1	Item no.: fine crystal handmade	2011/04	Item no.: fine crystal handmade	2011/00
	Height/glass:	325 mm	Height/glass:	265 mm	Height/glass:	265 mm	Height/glass:	265 mm
	Capacity/glass:	1200 ccm	Capacity/glass:	1400 ccm	Capacity/glass:	1400 ccm	Capacity/glass:	1400 ccm
	Design:	2022	Design:	2013	Design:	2013	Design:	2018
<b>PACKAGING</b>	Pieces/Bill unit:	1	Pieces/Bill unit:	1	Pieces/Bill unit:	1	Pieces/Bill unit:	1
<b>TYPE AND QUANTITY</b>	Bill units/MP:	1	Bill units/MP:	1	Bill units/MP:	1	Bill units/MP:	1
<b>BILL UNIT</b>	Length:	172 mm	Length:	303 mm	Length:	303 mm	Length:	303 mm
<b>DIMENSIONS</b>	Width:	172 mm	Width:	183 mm	Width:	183 mm	Width:	183 mm
	Height:	476 mm	Height:	458 mm	Height:	458 mm	Height:	458 mm
	Weight:	660 gr	Weight:	1047 gr	Weight:	1047 gr	Weight:	1047 gr
<b>MASTERPACK</b>	Length:	177 mm	Length:	314 mm	Length:	314 mm	Length:	314 mm
<b>DIMENSIONS</b>	Width:	177 mm	Width:	194 mm	Width:	194 mm	Width:	194 mm
	Height:	477 mm	Height:	464 mm	Height:	464 mm	Height:	464 mm
	Weight:	791 gr	Weight:	1223 gr	Weight:	1223 gr	Weight:	1223 gr
<b>EURO PALLET</b>	Bill units/pallet:	90	Bill units/pallet:	56	Bill units/pallet:	56	Bill units/pallet:	56
	Bill units/layer:	9	Bill units/layer:	14	Bill units/layer:	14	Bill units/layer:	14
	Layers/pallet:	10	Layers/pallet:	4	Layers/pallet:	4	Layers/pallet:	4
<b>CONTAINER PALLET</b>	Bill units/pallet:	182	Bill units/pallet:	100	Bill units/pallet:	100	Bill units/pallet:	100
<b>HIGH CUBE</b>	Bill units/layer:	14	Bill units/layer:	20	Bill units/layer:	20	Bill units/layer:	20
	Layers/pallet:	13	Layers/pallet:	5	Layers/pallet:	5	Layers/pallet:	5
<b>EAN</b>	 9 006206 323449		 9 006206 213344		 9 006206 213184		 9 006206 312924	
<b>BILL UNIT</b>								



Cornetto Fatto A Mano Decanter



Cornetto Single Decanter



Cornetto Mini Decanter



Decanter „O“  
Magnum

ITEM	Item no.: fine crystal handmade	1977/00	Item no.: fine crystal handmade	1977/13	Item no.: fine crystal handmade	1977/14	Item no.: fine crystal handmade	1414/26
	Height/glass:	325 mm	Height/glass:	325 mm	Height/glass:	282 mm	Height/glass:	385 mm
	Capacity/glass:	1200 ccm	Capacity/glass:	1200 ccm	Capacity/glass:	720 ccm	Capacity/glass:	2300 ccm
	Design:	2017	Design:	2003	Design:	2019	Design:	2005
<b>PACKAGING</b>	Pieces/Bill unit:	1	Pieces/Bill unit:	1	Pieces/Bill unit:	1	Pieces/Bill unit:	1
<b>TYPE AND QUANTITY</b>	Bill units/MP:	1	Bill units/MP:	1	Bill units/MP:	1	Bill units/MP:	1
<b>BILL UNIT</b>	Length:	172 mm	Length:	172 mm	Length:	291 mm	Length:	172 mm
<b>DIMENSIONS</b>	Width:	172 mm	Width:	172 mm	Width:	198 mm	Width:	172 mm
	Height:	476 mm	Height:	476 mm	Height:	224 mm	Height:	476 mm
	Weight:	660 gr	Weight:	660 gr	Weight:	625 gr	Weight:	1050 gr
<b>MASTERPACK</b>	Length:	177 mm	Length:	177 mm	Length:	-	Length:	177 mm
<b>DIMENSIONS</b>	Width:	177 mm	Width:	177 mm	Width:	-	Width:	177 mm
	Height:	477 mm	Height:	477 mm	Height:	-	Height:	477 mm
	Weight:	791 gr	Weight:	791 gr	Weight:	-	Weight:	1181 gr
<b>EURO PALLET</b>	Bill units/pallet:	90	Bill units/pallet:	90	Bill units/pallet:	128	Bill units/pallet:	90
	Bill units/layer:	9	Bill units/layer:	9	Bill units/layer:	16	Bill units/layer:	9
	Layers/pallet:	10	Layers/pallet:	10	Layers/pallet:	8	Layers/pallet:	10
<b>CONTAINER PALLET</b>	Bill units/pallet:	182	Bill units/pallet:	182	Bill units/pallet:	224	Bill units/pallet:	182
<b>HIGH CUBE</b>	Bill units/layer:	14	Bill units/layer:	14	Bill units/layer:	28	Bill units/layer:	14
	Layers/pallet:	13	Layers/pallet:	13	Layers/pallet:	8	Layers/pallet:	13
<b>EAN BILL UNIT</b>	 9 006206 312801		 9 006206 311279		 9 006206 313112		 9 006206 311316	



**Limited Editions:** TG reserves the right to offer glassware marked as "Limited Edition" in a certain amount and for a certain time period and under certain allocation criteria to Customer.



Ultra Magnum Decanter







Black Tie Occhio Nero Decanter



RIEDEL Decanter



RIEDEL Sakura Decanter

ITEM	Item no.: 2400/13 fine crystal handmade	Item no.: 2009/04 fine crystal handmade	Item no.: 2015/02 fine crystal handmade	Item no.: 2021/55 fine crystal handmade
	Height/glass: 240 mm Capacity/glass: 2000 ccm Design: 1994	Height/glass: 365 mm Capacity/glass: 1210 ccm Design: 2010	Height/glass: 365 mm Capacity/glass: 1210 ccm Design: 2015	Height/glass: 365 mm Capacity/glass: 1210 ccm Design: 2021
<b>PACKAGING</b>	Pieces/Bill unit: 1	Pieces/Bill unit: 1	Pieces/Bill unit: 1	Pieces/Bill unit: 1
<b>TYPE AND QUANTITY</b>	Bill units/MP: 1	Bill units/MP: 1	Bill units/MP: 1	Bill units/MP: 1
<b>BILL UNIT</b>	Length: 290 mm	Length: 172 mm	Length: 172 mm	Length: 172 mm
<b>DIMENSIONS</b>	Width: 290 mm	Width: 172 mm	Width: 172 mm	Width: 172 mm
	Height: 308 mm	Height: 476 mm	Height: 476 mm	Height: 476 mm
	Weight: 1301 gr	Weight: 990 gr	Weight: 990 gr	Weight: 990 gr
<b>MASTERPACK</b>	Length: 299 mm	Length: 177 mm	Length: 177 mm	Length: 177 mm
<b>DIMENSIONS</b>	Width: 299 mm	Width: 177 mm	Width: 177 mm	Width: 177 mm
	Height: 314 mm	Height: 477 mm	Height: 477 mm	Height: 477 mm
	Weight: 1440 gr	Weight: 1121 gr	Weight: 1121 gr	Weight: 1121 gr
<b>EURO PALLET</b>	Bill units/pallet: 48	Bill units/pallet: 90	Bill units/pallet: 90	Bill units/pallet: 90
	Bill units/layer: 8	Bill units/layer: 9	Bill units/layer: 9	Bill units/layer: 9
	Layers/pallet: 6	Layers/pallet: 10	Layers/pallet: 10	Layers/pallet: 10
<b>CONTAINER PALLET</b>	Bill units/pallet: 84	Bill units/pallet: 182	Bill units/pallet: 182	Bill units/pallet: 182
<b>HIGH CUBE</b>	Bill units/layer: 12	Bill units/layer: 14	Bill units/layer: 14	Bill units/layer: 14
	Layers/pallet: 7	Layers/pallet: 13	Layers/pallet: 13	Layers/pallet: 13
<b>EAN</b>				
<b>BILL UNIT</b>	9 006206 310036	9 006206 213085	9 006206 312153	9 006206 322008



Black Tie Smile Decanter



Black Tie Touch Decanter



Black Tie Bliss Decanter



Black Tie Smile Decanter  
Red

ITEM	Item no.: 2009/01 fine crystal handmade	Item no.: 2009/02 fine crystal handmade	Item no.: 2009/03 fine crystal handmade	Item no.: 2009/01S3 fine crystal handmade
	Height/glass: 365 mm Capacity/glass: 1410 ccm Design: 2010	Height/glass: 365 mm Capacity/glass: 1430 ccm Design: 2010	Height/glass: 365 mm Capacity/glass: 1210 ccm Design: 2010	Height/glass: 365 mm Capacity/glass: 1410 ccm Design: 2010
<b>PACKAGING</b>	Pieces/Bill unit: 1	Pieces/Bill unit: 1	Pieces/Bill unit: 1	Pieces/Bill unit: 1
<b>TYPE AND QUANTITY</b>	Bill units/MP: 1	Bill units/MP: 1	Bill units/MP: 1	Bill units/MP: 1
<b>BILL UNIT</b>	Length: 172 mm	Length: 172 mm	Length: 172 mm	Length: 172 mm
<b>DIMENSIONS</b>	Width: 172 mm	Width: 172 mm	Width: 172 mm	Width: 172 mm
	Height: 476 mm	Height: 476 mm	Height: 476 mm	Height: 476 mm
	Weight: 1000 gr	Weight: 990 gr	Weight: 990 gr	Weight: 1000 gr
<b>MASTERPACK</b>	Length: 177 mm	Length: 177 mm	Length: 177 mm	Length: 177 mm
<b>DIMENSIONS</b>	Width: 177 mm	Width: 177 mm	Width: 177 mm	Width: 177 mm
	Height: 477 mm	Height: 477 mm	Height: 477 mm	Height: 477 mm
	Weight: 1131 gr	Weight: 1121 gr	Weight: 1121 gr	Weight: 1131 gr
<b>EURO PALLET</b>	Bill units/pallet: 90	Bill units/pallet: 90	Bill units/pallet: 90	Bill units/pallet: 90
	Bill units/layer: 9	Bill units/layer: 9	Bill units/layer: 9	Bill units/layer: 9
	Layers/pallet: 10	Layers/pallet: 10	Layers/pallet: 10	Layers/pallet: 10
<b>CONTAINER PALLET</b>	Bill units/pallet: 182	Bill units/pallet: 182	Bill units/pallet: 182	Bill units/pallet: 182
<b>HIGH CUBE</b>	Bill units/layer: 14	Bill units/layer: 14	Bill units/layer: 14	Bill units/layer: 14
	Layers/pallet: 13	Layers/pallet: 13	Layers/pallet: 13	Layers/pallet: 13
<b>EAN</b>				
<b>BILL UNIT</b>	9 006206 212934	9 006206 212941	9 006206 212958	9 006206 212989



Black Tie Touch Decanter  
Red



Black Tie Bliss Decanter  
Red



RIEDEL Chinese Zodiac Rabbit Decanter  
Red/Yellow



RIEDEL Chinese Zodiac Dragon Decanter  
Red/Yellow

ITEM	Item no.: 2009/0253 fine crystal handmade	Item no.: 2009/0353 fine crystal handmade	Item no.: 2009/2351 fine crystal handmade	Item no.: 2009/2451 fine crystal handmade
	Height/glass: 365 mm Capacity/glass: 1430 ccm Design: 2010	Height/glass: 365 mm Capacity/glass: 1210 ccm Design: 2010	Height/glass: 365 mm Capacity/glass: 1210 ccm Design: 2023	Height/glass: 365 mm Capacity/glass: 1210 ccm Design: 2024
<b>PACKAGING</b>	Pieces/Bill unit: 1	Pieces/Bill unit: 1	Pieces/Bill unit: 1	Pieces/Bill unit: 1
<b>TYPE AND QUANTITY</b>	Bill units/MP: 1	Bill units/MP: 1	Bill units/MP: 1	Bill units/MP: 1
<b>BILL UNIT</b>	Length: 172 mm	Length: 172 mm	Length: 172 mm	Length: 172 mm
<b>DIMENSIONS</b>	Width: 172 mm	Width: 172 mm	Width: 172 mm	Width: 172 mm
	Height: 476 mm	Height: 476 mm	Height: 476 mm	Height: 476 mm
	Weight: 990 gr	Weight: 990 gr	Weight: 990 gr	Weight: 990 gr
<b>MASTERPACK</b>	Length: 177 mm	Length: 177 mm	Length: 177 mm	Length: 177 mm
<b>DIMENSIONS</b>	Width: 177 mm	Width: 177 mm	Width: 177 mm	Width: 177 mm
	Height: 477 mm	Height: 477 mm	Height: 477 mm	Height: 477 mm
	Weight: 1121 gr	Weight: 1121 gr	Weight: 1121 gr	Weight: 1121 gr
<b>EURO PALLET</b>	Bill units/pallet: 90	Bill units/pallet: 90	Bill units/pallet: 90	Bill units/pallet: 90
	Bill units/layer: 9	Bill units/layer: 9	Bill units/layer: 9	Bill units/layer: 9
	Layers/pallet: 10	Layers/pallet: 10	Layers/pallet: 10	Layers/pallet: 10
<b>CONTAINER PALLET</b>	Bill units/pallet: 182	Bill units/pallet: 182	Bill units/pallet: 182	Bill units/pallet: 182
<b>HIGH CUBE</b>	Bill units/layer: 14	Bill units/layer: 14	Bill units/layer: 14	Bill units/layer: 14
	Layers/pallet: 13	Layers/pallet: 13	Layers/pallet: 13	Layers/pallet: 13
<b>EAN</b>				
<b>BILL UNIT</b>	9 006206 213016	9 006206 213047	9 006206 325009	9 006206 325719



**Limited Editions:** TG reserves the right to offer glassware marked as "Limited Edition" in a certain amount and for a certain time period and under certain allocation criteria to Customer.



**Limited Editions:** TG reserves the right to offer glassware marked as "Limited Edition" in a certain amount and for a certain time period and under certain allocation criteria to Customer.



Ultra Decanter







Decanter „O“  
Single



Mosel Decanter



Medoc Decanter

ITEM	Item no.: fine crystal handmade	2400/14	Item no.: fine crystal handmade	1414/13	Item no.: fine crystal handmade	2019/03	Item no.: fine crystal handmade	2019/04
	Height/glass:	225 mm	Height/glass:	225 mm	Height/glass:	290 mm	Height/glass:	290 mm
	Capacity/glass:	1230 ccm	Capacity/glass:	980 ccm	Capacity/glass:	1150 ccm	Capacity/glass:	1110 ccm
	Design:	1994	Design:	2006	Design:	2019	Design:	2019
<b>PACKAGING</b>	Pieces/Bill unit:	1	Pieces/Bill unit:	1	Pieces/Bill unit:	1	Pieces/Bill unit:	1
<b>TYPE AND QUANTITY</b>	Bill units/MP:	1	Bill units/MP:	1	Bill units/MP:	1	Bill units/MP:	1
<b>BILL UNIT</b>	Length:	290 mm	Length:	290 mm	Length:	172 mm	Length:	172 mm
<b>DIMENSIONS</b>	Width:	290 mm	Width:	130 mm	Width:	172 mm	Width:	172 mm
	Height:	308 mm	Height:	130 mm	Height:	476 mm	Height:	476 mm
	Weight:	1101 gr	Weight:	595 gr	Weight:	842 gr	Weight:	845 gr
<b>MASTERPACK</b>	Length:	299 mm	Length:	-	Length:	177 mm	Length:	177 mm
<b>DIMENSIONS</b>	Width:	299 mm	Width:	-	Width:	177 mm	Width:	177 mm
	Height:	314 mm	Height:	-	Height:	477 mm	Height:	477 mm
	Weight:	1240 gr	Weight:	-	Weight:	973 gr	Weight:	976 gr
<b>EURO PALLET</b>	Bill units/pallet:	48	Bill units/pallet:	280	Bill units/pallet:	90	Bill units/pallet:	90
	Bill units/layer:	8	Bill units/layer:	20	Bill units/layer:	9	Bill units/layer:	9
	Layers/pallet:	6	Layers/pallet:	14	Layers/pallet:	10	Layers/pallet:	10
<b>CONTAINER PALLET</b>	Bill units/pallet:	84	Bill units/pallet:	527	Bill units/pallet:	182	Bill units/pallet:	182
<b>HIGH CUBE</b>	Bill units/layer:	12	Bill units/layer:	31	Bill units/layer:	14	Bill units/layer:	14
	Layers/pallet:	7	Layers/pallet:	17	Layers/pallet:	13	Layers/pallet:	13
<b>EAN</b>								
<b>BILL UNIT</b>	9 006206 310920		9 006206 311293		9 006206 313266		9 006206 313273	





Macon Decanter



Marne Decanter



Margaux Decanter

ITEM	Item no.: 2017/01	Item no.: 2017/02	Item no.: 2017/03
	<b>fine crystal handmade</b>	<b>fine crystal handmade</b>	<b>fine crystal handmade</b>
	Height/glass: 210 mm	Height/glass: 200 mm	Height/glass: 153 mm
	Capacity/glass: 1425 ccm	Capacity/glass: 1894 ccm	Capacity/glass: 1425 ccm
	Design: 2017	Design: 2017	Design: 2017
<b>PACKAGING</b>	Pieces/Bill unit: 1	Pieces/Bill unit: 1	Pieces/Bill unit: 1
<b>TYPE AND QUANTITY</b>	Bill units/MP: 1	Bill units/MP: 1	Bill units/MP: 1
<b>BILL UNIT</b>	Length: 260 mm	Length: 260 mm	Length: 260 mm
<b>DIMENSIONS</b>	Width: 260 mm	Width: 260 mm	Width: 260 mm
	Height: 240 mm	Height: 240 mm	Height: 240 mm
	Weight: 668 gr	Weight: 668 gr	Weight: 668 gr
<b>MASTERPACK</b>	Length: 266 mm	Length: 266 mm	Length: 266 mm
<b>DIMENSIONS</b>	Width: 266 mm	Width: 266 mm	Width: 266 mm
	Height: 244 mm	Height: 244 mm	Height: 244 mm
	Weight: 883 gr	Weight: 883 gr	Weight: 883 gr
<b>EURO PALLET</b>	Bill units/pallet: 84	Bill units/pallet: 84	Bill units/pallet: 84
	Bill units/layer: 12	Bill units/layer: 12	Bill units/layer: 12
	Layers/pallet: 7	Layers/pallet: 7	Layers/pallet: 7
<b>CONTAINER PALLET</b>	Bill units/pallet: 144	Bill units/pallet: 144	Bill units/pallet: 144
<b>HIGH CUBE</b>	Bill units/layer: 16	Bill units/layer: 16	Bill units/layer: 16
	Layers/pallet: 9	Layers/pallet: 9	Layers/pallet: 9
<b>EAN BILL UNIT</b>	 9 006206 312733	 9 006206 312740	 9 006206 312757





Decanter Mosel Machine-Made







Syrah Decanter



RIEDEL Apple NY Decanter



Performance Decanter

ITEM	Item no.: fine crystal machine-made	1416/03	Item no.: fine crystal machine-made	1486/13	Item no.: fine crystal machine-made	1466/13	Item no.: fine crystal machine-made	1496/13
	Height/glass:	285 mm	Height/glass:	245 mm	Height/glass:	195 mm	Height/glass:	245 mm
	Capacity/glass:	1320 ccm	Capacity/glass:	1040 ccm	Capacity/glass:	1500 ccm	Capacity/glass:	1040 ccm
	Design:	2022	Design:	2017	Design:	2014	Design:	2018
<b>PACKAGING</b>	Pieces/Bill unit:	1	Pieces/Bill unit:	1	Pieces/Bill unit:	1	Pieces/Bill unit:	1
<b>TYPE AND QUANTITY</b>	Bill units/MP:	6	Bill units/MP:	6	Bill units/MP:	6	Bill units/MP:	6
<b>MASTERPACK</b>	Length:	340 mm	Length:	446 mm	Length:	417 mm	Length:	446 mm
<b>DIMENSIONS</b>	Width:	230 mm	Width:	297 mm	Width:	282 mm	Width:	297 mm
	Height:	295 mm	Height:	264 mm	Height:	202 mm	Height:	264 mm
	Weight:	2485 gr	Weight:	2206 gr	Weight:	2042 gr	Weight:	2048 gr
<b>EURO PALLET</b>	Bill units/pallet:	360	Bill units/pallet:	252	Bill units/pallet:	324	Bill units/pallet:	252
	Bill units/layer:	60	Bill units/layer:	36	Bill units/layer:	36	Bill units/layer:	36
	Layers/pallet:	6	Layers/pallet:	7	Layers/pallet:	9	Layers/pallet:	7
<b>CONTAINER PALLET</b>	Bill units/pallet:	630	Bill units/pallet:	432	Bill units/pallet:	594	Bill units/pallet:	432
<b>HIGH CUBE</b>	Bill units/layer:	90	Bill units/layer:	54	Bill units/layer:	54	Bill units/layer:	54
	Layers/pallet:	7	Layers/pallet:	8	Layers/pallet:	11	Layers/pallet:	8
<b>EAN</b>								
<b>BILL UNIT</b>	9 006206 323265		9 006206 525898		9 006206 311828		9 006206 528233	



### 1. ADDITIONAL COSTS FOR CUSTOMERS CALIBRATION AND POUR AID

- No stock production. Manufacturing after fix order.
- per glass size (for re-orders as well).
- A quantity +/- 10% compared to the order quantity has to be accepted by the client.

The following prices are given for special calibrations and pour aid as per the German Calibration Act, if they are not included in the collection according to the price list:

prices per piece and per glass size orders exceeding: (Single marks / Double marks)	120 pcs.	600 pcs.	2500 pcs.
machine blown glass	€ 0.85	€ 0.80	on request

### 2. SIGNETS & VIGNETTES - SILK SCREEN PRINTING (WITHOUT CALIBRATION AND POUR AID)

- On bowl only.
- No stock production. Manufacturing after fix order.
- Minimum order quantity 60 pieces per glass size (for re-orders as well).
- A quantity +/- 10% compared to the order quantity has to be accepted by the client.

For the first production you have to pay non-recurring tool costs of Euro 175.- if you have a appropriate artwork. If we have to re-produce the artwork we have to charge approx Euro 300.- May we ask you to send us your artwork in order or us to determine the appropriate technique to execute your vignette. Silk screen printing costs for Gold and Platinum upon request.

pieces	prices per piece and per glass size orders exceeding: for stem glasses machine-made; color: matt white
60 pcs.	€ 3.99
120 pcs.	€ 2.99
240 pcs.	€ 1.65
300 pcs.	€ 1.25
420 pcs.	€ 1.10
540 pcs.	€ 0.75
1.200 pcs.	€ 0.55
2.500 pcs.	€ 0.45
5.000 pcs.	€ 0.40
10.000 pcs.	€ 0.35



SINGLE POUR LINE

DOUBLE POUR LINE

SEPARATE PROCESS

### 3. SIGNETS & VIGNETTES - SILK SCREEN PRINTING (INCLUDING CALIBRATION AND POUR AID)

- No stock production. Manufacturing after fix order.
- Minimum order quantity 120 pieces per glass size (for re-orders as well).
- A quantity +/- 10% compared to the order quantity has to be accepted by the client.

prices per piece and per glass size orders exceeding:	120 pcs.	240 pcs.	600 pcs.	2500 pcs.
For stem glasses, machine made Color: matt white	€ 2.75	€ 1.65	€ 1.20	on request

For the first production you have to pay a one time tool costs of Euro 175.- you have the appropriate artwork. If we have to re-produce the artwork we have to charge approx Euro 300.-. May we ask you to send us your artwork in order to determine the appropriate technique to execute your vignette. Silk screen printing costs for Gold and Platinum upon request.

### 4. INFORMATION ABOUT SILK SCREEN DECORATION:

In decorating glass with the screen printing process, colour is pressed through a silk screen to the glass surface and fixed to the glass during a temperature treatment. The colours, used by RIEDEL, are organic colours without heavy metals (such as lead, barium, etc.) or other toxic components. These colours have a high dishwasher resistance, but compared with ceramic colours a lower mechanical resistance.

### 5. ATTENTION:

The water hardness for cleaning glass, should not be less than 3° d.H.

Glasses with organic colours should be placed in the dishwasher in a way that they cannot make contact with each other during the washing process. If cleaning the glasses by hand, please do not use a scouring brush or abrasive detergents.

Be aware that fully desalinated water is extremely aggressive to both the glass surface and screen print decoration.

Over/underproduction (+10/-10 %) may be possible and will be billed accordingly.



SEPARATE  
PROCESS

## MICROFIBER POLISHING CLOTH

- Wash at boiling temperature (to kill bacteria) with odorless soap
- Should be machine washed at min. 170° F/60° C
- Never use fabric softener when rinsing your microfiber polishing cloth (avoids grease film on surface)



## CARING FOR YOUR RIEDEL CRYSTAL

- All RIEDEL glasses are DISHWASHER SAFE for 1,000 plus cycles.
- To avoid stains: use soft water (low mineral content)
- To avoid scratches: Avoid glass contact with other glass or metal
- To remove stains: use white vinegar
- If available use a stemware rack

## IF WASHING BY HAND

- Wash the glass under warm water (use detergent and rinse the glass carefully)
- Glass polishing: Use two polishing cloths, never hold the glass by the base to polish the bowl
- Stem snap: Occurs through mishandling = torque or bend pressure at the stem
- Storage: Avoid glass storage in kitchen cabinets which have strong aromas that translates into glass



FOR INFORMATION ON GLASS CARE  
AND HOW TO WASH GLASSWARE,  
VISIT [RIEDEL.COM](http://RIEDEL.COM).

## For a perfect result

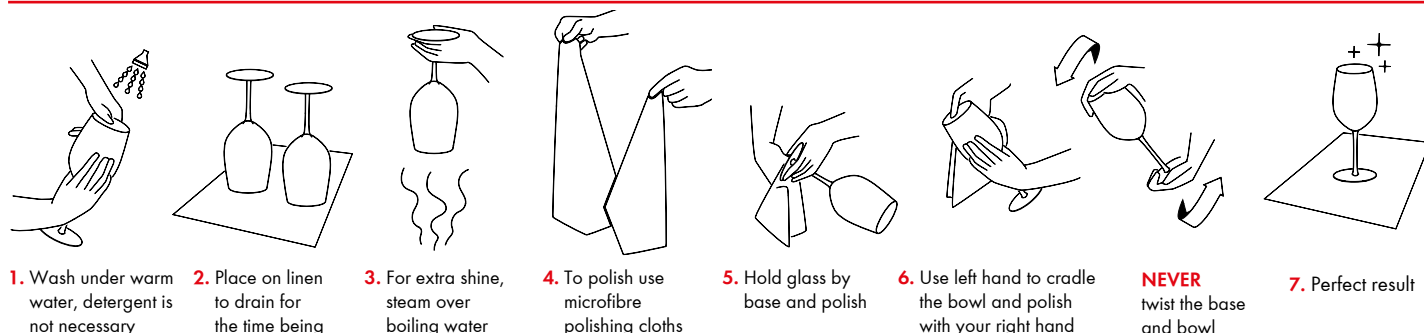

1. Wash under warm water, detergent is not necessary
2. Place on linen to drain for the time being
3. For extra shine, steam over boiling water
4. To polish use microfibre polishing cloths
5. Hold glass by base and polish
6. Use left hand to cradle the bowl and polish with your right hand
- NEVER** twist the base and bowl
7. Perfect result

CAUTION: A Riedel glass is a grape varietal specific wine tool! This shape works best with wines made from specific grapes. Please read the instructions below to guarantee maximum enjoyment. Riedel has researched the

grape varietal sensation, leading to the conclusion, on which the world's wine experts agree; that the enjoyment of aroma, taste, texture and finish of a wine, is maximized by using the right "WINE TOOL"



## Rules when handling connoisseur glasses



### 1 Filling the glass

Do not over-pour. This will ensure maximum development of the wine's bouquet, and also provide the most elegant table setting.



### 2 Holding the glass

The appropriately filled glass should always be held by the stem rather than the bowl.



### 3 Swirling the glass

Carefully swirling the glass allows oxygen into the wine by increasing its surface area and helps release the wine's rich, mature aroma.



### 4 Why and how to decant wines

To decant wine means to transfer it from its bottle to a decanter or carafe before drinking. During storage or aging, wine can develop a solid deposit or sediment at the bottom of the bottle. Decanting is an easy means of separating the sediment from the wine. It also helps the wine breathe, as the greater surface diameter lets more oxygen reach the wine than the bottle does.



### 5 Wine temperature

Before decanting/or serving wine, store it at appropriate temperatures (red wine 59-63°F, 15-17°C, white wines at 50-54°F, 10-12°C). The proper serving temperature enhances the quality of the wine by allowing it to fully develop its characteristic aromas and flavours.

(1) *Riedel*

(2) **RIEDEL**

The RIEDEL TRADEMARK dates from the Art Nouveau period at the end of the nineteenth century, and was used for RIEDEL glassware made in Bohemia from 1890 to 1925. In 1996, to commemorate RIEDEL'S 240<sup>th</sup> anniversary, we reintroduced this trademark for all our handmade and hand-finished products. The distinctive Riedel signature is now featured on the base of all these products. This signature trademark (1) helps our customers to distinguish immediately between handmade, hand-finished products and those made by machine (2). Our machine-made products carry this trademark. The RIEDEL glass dynasty is built on the creative energies of a long line of glassmakers. The story begins in 1756 in Bohemia and continues right down to the united Europe of today, taking in on the way some of the most dramatic events in European history.

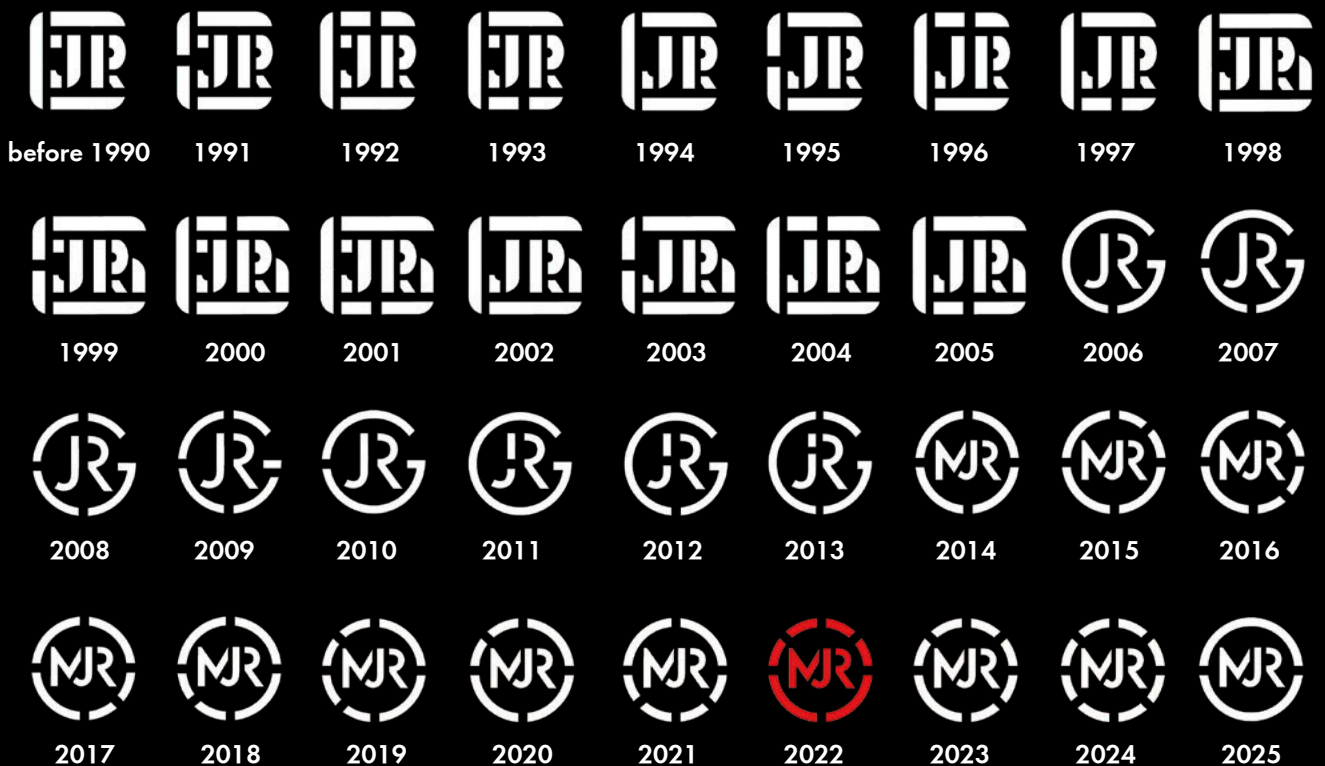

# HANDMADE ITEMS

## FOR COLOURED DECANTERS:

- minimum order of 25 decanters
- all handmade decanters can be customized BUT limited edition colours can not be used, also metal colours like gold are not available
- No samples will be sent prior, note that colours cannot be predicted due to the fact, that this is depending on how thin the glass is blown.
- 50% Pre-payment applies.
- For customized items, Riedel would ask that customers be amenable to accepting an over or under production of 20%.

### Exception: Face to Face

- minimum order 15 pieces **WITHOUT** any upcharge.
- Process: please provide profile image, we will than do a drawing which has to be approved by the customer prior production.
- No samples will be available prior production.
- All customized items are excluded from promotions.



## FOR DECANTER (SHAPES):

- existing shape, which is no longer in collection, (discontinued) can be reproduced
- a minimum order of 50 decanters
- prices on request

## FOR CUSTOMIZED STEMWARE:

- Minimum order quantity: 175 pcs.
- 50% Pre-payment applies.
- RIEDEL Fatto A Mano only 2 colours.





# CUSTOMIZED ,OCCHIO NERO' DECANTER

## Pre-Arrangements

- Before order can be confirmed we need to get the logo from the customer in order to enable us to check whether it is feasible from a technical point of view.
- The line width must at least 2 mm at all parts of the logo.
- 50% Pre-payment applies.

## Sampling

- Even if only one single sample is required we need a high quality stamp as per attached picture, therefore we have to charge € 500 for the sample.
- Stamp lasts for approx: 500 prints
- re-order of existing stamp motive € 300
- Sample has to be approved by the customer.

## Basic parameters for orders

- Minimum order quantity: 50 pcs
- For customized items, Riedel would ask that customers be amenable to accepting an over or under production of 10%.



BLACK TIE  
OCCHIO NERO  
2009/04

**Offer valid for alteration of logo etc. within the elliptical-shaped dent, variations of shape of dent have to be quoted separately.**



Example for stamp

**Embossing is possible in 3 basic shapes:**

- 1 Circle of 60 mm
- 2 Small oval of 69 x 41 mm
- 3 Large oval of 76 x 50 mm

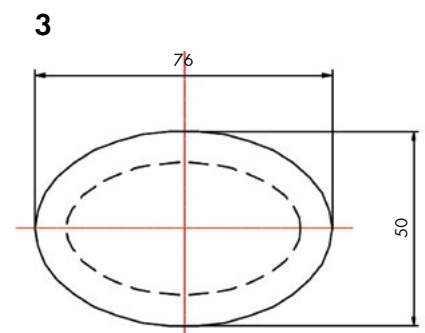
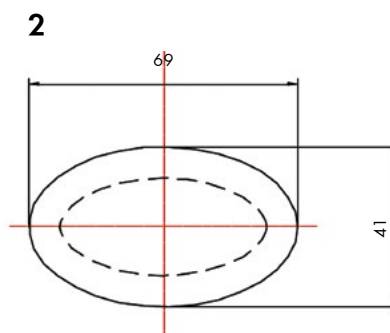
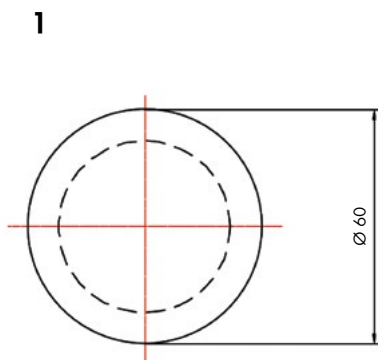



MAXIMILIAN J. RIEDEL  
11<sup>TH</sup> GENERATION



## GO GREEN - SUSTAINABILITY

### Our Glassware

- Durable / sustainable product - long lasting and reusable for many years
- Up to 50% made from recycled Riedel crystal within our factories
- Crystal-Glass is inert and does not react with substances or materials that it comes into contact with (in contrast to plastic which, for example, can release Bisphenol A (BPA))
- Production processes are completely BPA-free / no plastic
- Our crystal glass is compliant with all known migration limits and is fully certified for safe usage with food and drinks
- 100% recyclable

### Our Packaging



- Green Dot certified (production sites Germany - the company is committed to recovery and recycling)
- 45% FSC® - Forest Stewardship Council
- Reclay whole system (production sites Austria)
- Recyclable
- We work with sustainability-committed suppliers only. For example, with Mondi RIEDEL has won a Sustainability Award for the jointly developed packaging solution from Riedel Performance

### Our Factories



- Implemented environment certificates ISO 14001: 2015 and ISO 50001: 2011
- Main raw materials are locally sourced e.g. quartz sand from Hirschau (short transport routes)
- Energy-saving projects include: compressed air, burner technology, energy efficient drives, LED lighting, waste heat recovery, water saving measures
- Substitution of hazardous substances with more environmentally friendly options

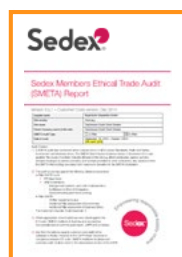

[www.riedel.com](http://www.riedel.com)

# RIEDEL

„sensory“  
work shop

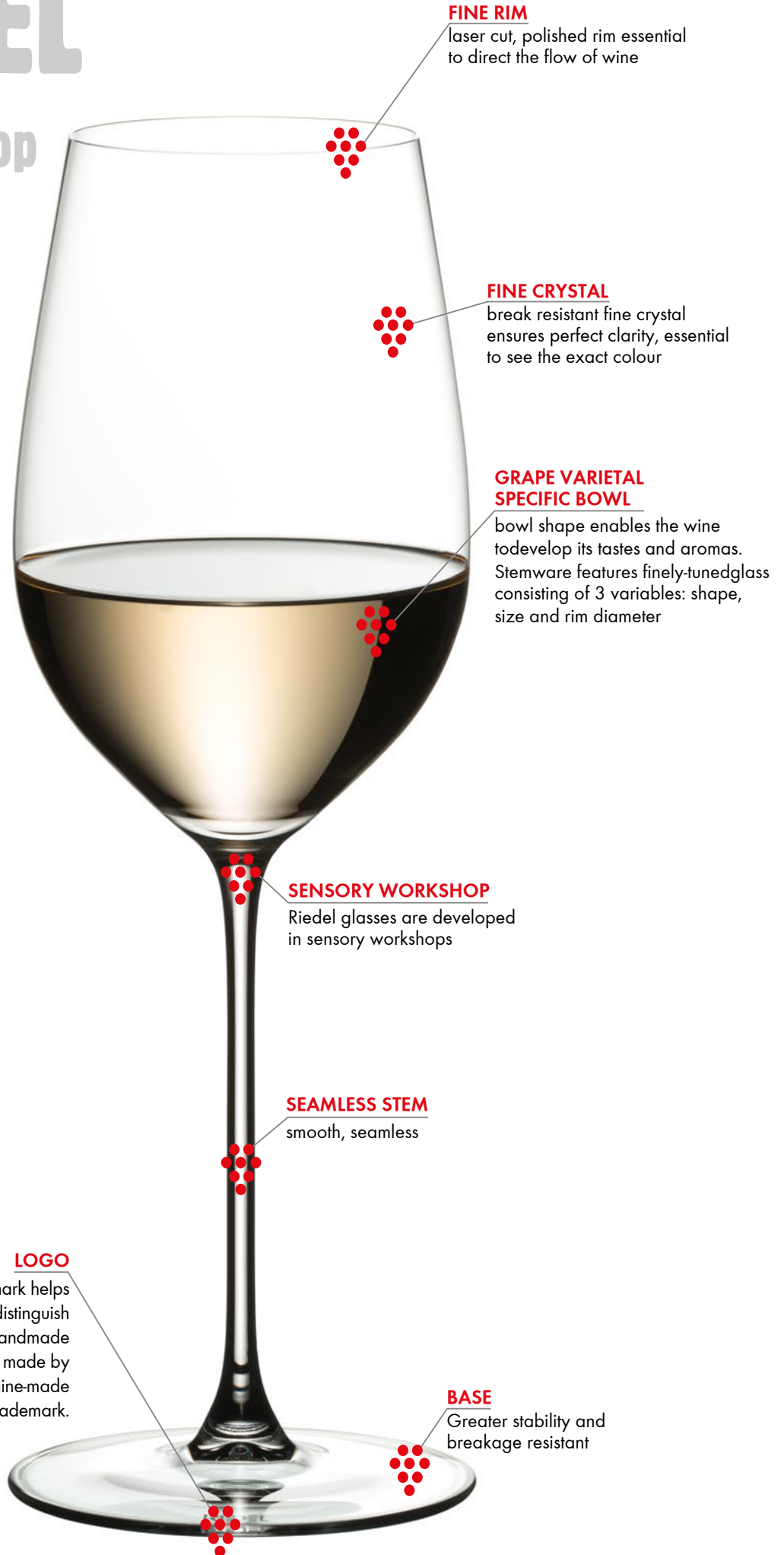

**FINE RIM**

laser cut, polished rim essential to direct the flow of wine

**FINE CRYSTAL**

break resistant fine crystal ensures perfect clarity, essential to see the exact colour

**GRAPE VARIETAL SPECIFIC BOWL**

bowl shape enables the wine to develop its tastes and aromas. Stemware features finely-tuned glass consisting of 3 variables: shape, size and rim diameter

**SENSORY WORKSHOP**

Riedel glasses are developed in sensory workshops

**SEAMLESS STEM**

smooth, seamless

**LOGO**

This *Riedel* signature trademark helps our customers to distinguish immediately between handmade products and those made by machine. Our machine-made products carry this **RIEDEL** trademark.

**BASE**

Greater stability and breakage resistant

# GENERAL TERMS AND CONDITIONS OF CONTRACT OF TIROLER GLASHÜTTE GMBH 2023 ("TG").

## 1. Scope of Application.

All provisions of goods and services by Tiroler Glashütte GmbH ("TG") to or for the benefit of each customer of TG (the "Customer") shall be subject to the following General Terms and Conditions of Contract (the "T&C"), unless otherwise expressly agreed upon in writing and signed by TG. By placing an order with TG for the supply of products sold by TG (the "Products") and/or for services provided by TG or otherwise accepting the supply of Products and/or services by TG (or any part thereof), Customer (a) agrees to purchase the Products and services on and subject to the T&C and (b) acknowledges and agrees that, in respect of any other terms and conditions (including terms and conditions accompanying any purchase order or received from Customer): (I) those terms and conditions are not effective and TG will not be bound by them; (II) the T&C supersedes and replace any such terms and conditions in their entirety; unless such terms and conditions are duly acknowledged and expressly agreed to in writing and signed by TG. For the avoidance of doubt, the acceptance of orders or performance of services by TG shall not be regarded as the grant of any entitlement to future fulfillment of orders or provision of services by TG, and nothing in the T&C shall be construed as creating a relationship of exclusivity between Customer and TG.

## 2. Orders.

**2.1.** All orders by Customer (the "Orders", or each an "Order") shall become legally effective and binding on Customer upon TG's delivery of its written acceptance of each such Order (an "Order Confirmation") or, in the absence of such Order Confirmation, by delivery of the Products comprising such Order to Customer. Customer may modify any Order at any time before TG's delivery to Customer of the Order Confirmation for such Order (or in the absence of such Order Confirmation, delivery of the Products comprising such Order), but under no circumstances shall Customer be permitted to modify any Order more than five (5) calendar days after placing such Order. TG will communicate expected lead-times of Products in the respective Order Confirmation (in this context also see **Clause 6.4.**)

**2.2.** Once an Order is confirmed by TG or delivered to Customer, such Order may not be cancelled by Customer except with the prior consent in writing of TG, in which case Customer will be liable to TG for all costs, expenses and other losses incurred by TG in connection with such cancellation.

**2.3.** TG reserves the right, in its sole discretion, to (I) reject any Order at any time without giving any reasons before sending the Order Confirmation (or, in the absence of an Order Confirmation, before delivery); (II) cancel any Back Orders (see **Clause 2.9**) at any time by giving Customer notice of such cancellation; (III) accept Orders only with respect to amounts that from experience correspond with usual quantities ordered by enterprises of comparable size; and/or to (IV) terminate any framework agreement possibly existing at any time with immediate effect without giving any reasons.

**2.4.** Customer shall comply on all its Orders with all guidelines communicated by TG regarding minimum Order values and minimum Product Orders, including those set out in the T&C.

**2.5.** Special Orders: Orders for any Products not featured in the applicable Price Books ("**Special Orders**") require a 50% deposit. Special Orders can be combined with any other Orders to meet Order minimums. Quantities of Special Orders can only be ordered in full master packs. No returns or cancellations on Special Orders are permitted.

**2.6. Value Packs:** Any preferential conditions on which Customers may purchase packs containing free Products ("**Value Packs**") must - to the extent legally permissible - be passed on to the end-consumer in at least the same amount. Customer may not un- or repack Value Packs and may not sell any merchandise included in Value Packs individually.

**2.7. Limited Editions:** TG reserves the right to offer Products marked as "Limited Edition" in a certain amount and for a certain time period and under certain allocation criteria to Customer.

**2.8.** Glassware marked as "**On-Premise Glass Collection/Glassware**" is reserved for the hospitality industry ("**On-Premise Customers**") only, and is not intended for resale, the retail trade and/or for end-consumers.

**2.9. Back Orders:** If an ordered Product is out of stock, TG will notify Customer and will automatically place the Product on back order, and send the stock as soon as it becomes available ("**Back Order**"). If Customer does not want the Product comprising such Back Order, Customer needs to advise TG immediately after receipt of such Back Order notification accordingly in writing, otherwise Back Orders cannot be cancelled by Customer.

**2.10.** Customer acknowledges that the packaging and labeling of the Products as designed and implemented by TG is critical to maintain the recognition and the image of the respective Brands (as defined in **Clause 3.2.**). Without the prior written consent of TG, Customer shall not modify or remove or otherwise make illegible or unreadable any packaging, labeling, tags, markings or other items, such as QR Codes, promotional materials or instructions, howsoever affixed to the Products themselves or to their packaging or accompanying the Products.

**2.11.** The Products shall not be unpacked from their original packaging as shipped to Customer or be repacked by Customer, but shall be sold by Customer in its original packaging, unless explicitly priorly authorized by TG in writing.

**2.12.** In the event that TG explicitly authorizes Customer in writing to unpack

(unwrap) and/or repack Products (collectively, "**Authorized Packaging Changes**"), Customer shall ensure that the unpacked and/or repackaged Products and the packaging used by the Customer (the "**Customer Packaging**") comply with all applicable laws, rules, and regulations, including but not limited to those laws, rules, and regulations that concern such Products' and Customer Packaging's labelling, marking, tagging, waste management, boxing, marketing, storage, distribution, handling, cleaning and sale, and Customer shall indemnify, defend, and hold harmless TG and its affiliates for any violations or alleged violations thereof. TG and its affiliates shall not be responsible for and Customer shall indemnify, defend and hold TG and its affiliates harmless from, and against, any and all claims, suits, losses, damages, demands, injuries, costs and expenses (including reasonable attorney's fees and costs) arising out of or related to Authorized Packaging Changes, including but not limited to any damage or loss arising out of the labelling, marking, tagging, waste management, boxing, marketing, storage, distribution, handling, cleaning and/or sale of the Products or of the Customer Packaging.

**2.13.** In the event that Customer elects to purchase TG's Product comprising two wine glasses within packaging permitting Customer's inclusion of one bottle of wine (the "**2 Glasses 1 Bottle Product**"), Customer shall ensure that the 2 Glasses 1 Bottle Product complies with all applicable laws, rules, and regulations, including but not limited to those laws, rules, and regulations that concern such 2 Glasses 1 Bottle Product's labelling, marking, tagging, waste management, packaging, marketing, storage, distribution, handling, cleaning and sale, and Customer shall indemnify, defend, and hold harmless TG and its affiliates for any violations or alleged violations thereof. TG and its affiliates shall not be responsible for and Customer shall indemnify, defend and hold TG and its affiliates harmless from, and against, any and all claims, suits, losses, damages, demands, injuries, costs and expenses (including reasonable attorney's fees and costs) arising out of or related to 2 Glasses 1 Bottle Products, including but not limited to any damage or loss arising out of the labelling, marking, tagging, waste management, boxing, marketing, storage, distribution, handling, cleaning and/or sale of the 2 Glasses 1 Bottle Product.

**2.14.** Customer understands that TG's ability to effect proper quality control measures, including but not limited to quality control oversight over the Brands, Trademarks and the Products, requires TG's unfettered ability to track its inventory at all stages of the Products' supply chain. Accordingly, Customer acknowledges and agrees that it will not under any circumstances remove, deface, obscure, cover up, or otherwise make illegible or unreadable any unique identifying label, mark, tag, scan code, or identification number (including but not limited to bar codes, RFIDs, and QR codes) that is howsoever affixed to any Product or the packaging of any Product.

**2.15.** In the event that Customer, as determined by TG in its sole discretion, is found to have violated any part of **Clause 2.10, 2.11, 2.12, 2.13 or 2.14**, Customer's status as an authorized purchaser and as the case may be, as well reseller of the Products shall be subject to immediate termination, and TG shall reserve all rights and remedies it may have against Customer pursuant to these T&C, any other agreement entered into or otherwise governing the relationship between TG and Customer, and applicable law.

**2.16.** TG does not provide Customers with any kind of marketing support, unless decided by TG in its sole discretion on an individual basis case by case. The granting of any kind of marketing support by TG to a Customer does not create any further claims by Customer for continued support. Customer will not be reimbursed for any kind of investments or promotional events or for any kind of promotional material regarding the Brands (see **Clause 3.2.**), irrespectively if Customer purchased such material from TG or from a third party.

## 3. Customer Obligations.

Customer hereby agrees at all times to observe and abide by the obligations (the "**Customer Obligations**") as outlined in this **Clause 3.** of the T&C.

**3.1.** Retail-Customers: Retail-Customers may sell retail Products received from TG to end-user consumers. Active sales to certain groups of resellers or to any kind of resellers in certain territories, which TG has exclusively reserved for itself or for third party dealers, are prohibited. TG will inform Customer respectively. Passive sales are exempted from the above restriction. Provisions in the selective distribution network remain unaffected by this **Clause 3.1.**

**3.2.** Customer acknowledges its obligation to maintain and promote the extremely high standard of the Products reputation as comprising some of the world's finest glassware, the goodwill symbolized by the "Riedel", "Spiegelau" and "Nachtmann" brands (the "**Brands**"), and the associated trademarks (the "**Trademarks**") and trade dress and Products, and to further refrain from any conduct that could be viewed as disparaging or otherwise having a negative impact on the image of the Products, the Brands, the Trademarks, TG and its affiliates, and shall include, but shall not be limited to, the selling of the Products to or via mass merchandisers or discount stores that were not specifically authorized by TG in writing, and the selling of the Products next to other goods that are infringing upon the intellectual property rights of TG or of its licensors.

**3.3.** Customer will conduct its activities strictly in accordance with the T&C and all applicable laws and regulations. In the event that Customer is found to have violated any part of **Clause 3.**, Customer's status as an authorized purchaser and as the case may be, as well reseller of the Products shall be subject to immediate termination, and

# GENERAL TERMS AND CONDITIONS OF CONTRACT OF TIROLER GLASHÜTTE GMBH 2023 ("TG").

TG shall reserve all rights and remedies it may have against Customer pursuant to these T&C, any other agreement entered into or otherwise governing the relationship between TG and Customer, and applicable law.

## 4. Prices.

The prices for the Products and/or services are as set out in the applicable printed and/or digital Price Books provided to Customer by TG from time to time (the "Price Books"). TG reserves the right to change the Product assortment and/or the service assortment as well as the prices for its Products and/or services from time to time, and the prices applicable at the time an Order is placed are those that apply to the Products and services purchased. Unless otherwise stated in TG's applicable Payment & Delivery Terms (as defined in **Clause 5.1**) all prices are stated net per sales unit, EX WORKS („EXW", INCOTERMS 2020) TG warehouse, Germany, excluding the packaging for shipment. TG issues its invoices in Euros or – at TG's sole discretion – in another currency depending on the Customer address. Prices are exclusive of statutory VAT or other taxes, fees or duties. If VAT is payable, it will be stated separately in TG's invoice.

## 5. Terms of Payment.

**5.1.** The payment and delivery terms applicable to Customer are set forth separately in TG's "Payment & Delivery Term Sheets" (the "Payment & Delivery Terms"), which are hereby expressly incorporated into and form an integral part of these T&C. TG reserves the right (I) to change its Payment & Delivery Terms from time to time, with any such changes applying to future Orders placed, or (II) to suspend fulfillment of any agreement with Customer, if TG has reason to believe that such change/suspension is necessary due to Customer's financial situation or payment history.

**5.2.** TG may ask for a payment confirmation to be issued by a bank accepted by TG. Payment will be deemed effected as soon as TG is able to freely dispose of the same at its registered office. If payments are effected in freely convertible currencies other than the invoicing currency, Customer will bear the exchange rate risk. Any bank charges are at Customer's expense. Customer acknowledges its obligation to pay default interest of 11% p.a. as of the due date. Any claims, counterclaims or claims for compensation of Customer shall not entitle Customer to any extension of the period stipulated for payment.

**5.3.** An eventually granted cash discount may only be deducted, if all outstanding invoices have been fully paid by Customer.

**5.4.** TG is not obliged to accept checks or bills of exchange; they will only be credited as payment subject to them actually being honored to the value to which they are at disposal. All costs incurred in connection with acceptance of bills of exchange or checks, in particular discounting charges and interest, shall be borne by Customer.

**5.5.** Each delivery by instalment shall be deemed an independent transaction for billing and payment purposes.

**5.6.** In the event of default in payment under these T&C by more than sixty (60) days past due, TG may suspend all deliveries until the full outstanding amount has been credited to TG's account. Although TG may accept new Orders, these will not be processed and/or delivered.

**5.7.** If (a) Customer defaults in payment under these T&Cs by more than sixty (60) days past due OR (b) all or substantially all of the assets of Customer are sold or otherwise transferred; OR (c) there is a change in control with respect to Customer; OR (d) the legal form of Customer is changed; OR (e) in the reasonable opinion of TG, Customer's financial situation changes or deteriorates materially (e.g. a bill of exchange or cheque provided by Customer is not honored); OR (f) at any time TG considers (acting reasonably) that Customer is a credit risk, THEN: (g) all outstanding accounts receivable, also under bills of exchange, will become due for payment immediately irrespective of their due date and (h) TG shall be entitled to terminate or cancel all current contracts and/or confirmed Orders, request damages in lieu of performance, stop any or all deliveries, require proper security before making any delivery or effect delivery only against full cash amount payable on delivery (if Customer has already advanced any payments in relation to terminated or cancelled Orders, TG will refund those amounts or allocate/offset them accordingly); and (i) TG will retain title to Products that have not been paid for as described under **Clause 12**. and TG may ascertain and collect any such Products that are in the possession, custody or control of Customer.

## 6. Delivery and Passing of Risk.

**6.1.** Unless otherwise stated in TG's applicable Payment & Delivery Terms or agreed in writing by TG, all deliveries will be effected EX WORKS („EXW", INCOTERMS 2020) TG warehouse, per address RSN Logistik GmbH, Weiden i.d. Of., Germany.

**6.2.** Unless otherwise stated in TG's applicable Payment & Delivery Terms, if so requested by Customer and agreed in writing by TG, Products can be shipped to a different destination. Save where otherwise agreed, TG is entitled to determine the kind of shipment (in particular the forwarding agency, shipment route, packaging). Products will be shipped at Customer's sole cost and risk.

**6.3.** If Products are shipped to a different destination upon Customer's request, the risk shall pass to Customer on the Products' surrender to the person designated to carry out shipment. Customer shall assume all risk to Products during transportation thereof, TG shall not be obligated to replace or credit Customer for Products that are stolen, lost,

broken, damaged, or otherwise altered during or as a result of their transportation, and Customer shall be solely responsible for filing any and all claims for loss or damage with the responsible entity or entities.

**6.4.** Deliveries will be made by TG according to its operational capabilities. Communicated lead-times refer to TG ex-warehouse dates and are estimates only and are not binding; lead-times for Special Orders and Limited Editions will be communicated to Customer on a case-by-case basis, also refer to TG ex-warehouse dates and are estimates only and are not binding. To the extent permitted by law, TG will not be liable for its failure to make any delivery by the estimate date and any claims for damages due to non-performance or delayed performance are excluded, and Customer waives any and all claims against TG and its affiliates for damages and other liabilities arising from or due to TG's actual or alleged non-performance or delayed performance.

**6.5.** TG will observe commercially reasonable efforts in its observance of these T&C, which observance shall be subject to unforeseeable events or events not otherwise contemplated by these T&C. TG will not be responsible for any delay or failure to perform its obligations under these T&C or otherwise, which arises out of or is due to unforeseeable events or events independent of the intention of the parties, such as events of force majeure ("Force Majeure Event"), including, by way of example and not of limitation, all events of pandemics, epidemics, war, terrorist actions, interventions, instructions and prohibitions of official authorities, delays in transport and customs clearance, transport damage, inclement weather, lack of energy, financial crisis, labor conflicts as well as delays in delivery on the part of suppliers for any reasons. Delivery times will be prolonged where any Force Majeure Event occurs. If Products, which are ready for shipment, cannot be shipped through no fault of TG or if Customer does not want Products to be shipped, TG may store Products at Customer's cost and risk, whereby delivery shall be deemed fulfilled. The agreed payment terms are not changed thereby.

**6.6.** Retail-Products are shipped in brown master packs (order units). The master pack is only to protect the retail-Products and is not designed to be used as shippable outer carton and may not be used as such. Any other use of the master pack, in particular its use for shipping, is the sole responsibility and risk of Customer.

**6.7.** The cost of any special packing and packing materials used in relation to the Products are at Customer's sole expense notwithstanding that such cost may have been omitted from any Price Book or quotation. Customized packaging is subject to the signing of a separate packaging agreement.

**6.8.** Regarding Special Orders, TG reserves the right to supply the quantity deviations of +/- 5% of the quantity ordered (the "Permitted Deviation"), which is customary within the industry. Provided that TG's fulfillment of any Special Order is within the Permitted Deviation, the quantity actually delivered shall be paid for by Customer in full.

**6.9.** If Products are to be delivered at the TG warehouse, TG will advise Customer about twenty (20) business days in advance of the respective delivery date. Partial deliveries of an Order (i.e. deliveries by instalments) are permitted. Customer shall pick-up all available and prepared Products, including partial deliveries of an Order, within ten (10) business days as of the communicated delivery date. If Customer informs TG that Customer will not collect the respective delivery or if Customer fails to pick such delivery within this ten (10) business days window, TG shall be entitled to either (I) partially or in total cancel the respective Order or (II) to store the Products at Customer's cost (at EUR 20 net per pallet per week) and risk, whereby delivery to Customer shall be deemed fulfilled and will be invoiced.

## 7. Partial Delivery.

Deliveries by instalments (i.e. partial deliveries) shall be permitted and may be invoiced. If TG delivers any of the Products by instalments, and any one of those instalments is defective/non-compliant for any reason (as defined in **Clause 8.**), it is not a repudiation of the contract of sale formed by the T&C.

## 8. Notice of Defects/Non-Compliance, Warranty.

**8.1.** Any defect claims or non-compliances with the contract must be made in writing within **twenty-eight (28) days** from the date of delivery of the Products and in any event prior to their use or re-sale, including a detailed description and photos of the defect or the non-compliance; otherwise the Products are deemed accepted by Customer.

**8.2.** Customer shall assume all risk to Products during transportation thereof. TG shall not be obligated to replace or credit Customer for Products that are stolen, lost, broken, damaged, or otherwise altered during or as a result of their transportation, and Customer shall be solely responsible for filing any and all claims for loss or damage with the responsible entity or entities.

**8.3.** Any defects or non-compliances caused as result of a Force Majeure Event shall be excluded from TG's warranty.

**8.4.** For glass clouding a warranty of 2 (two) years as of the respective production date (bottom stamp) is granted. No warranty is provided for mechanical damages to the surface.

**8.5.** Customer acknowledges that deviations may occur between Products from the same series for technical reasons and because of the materials used in the course of the production of glass products, in particular with respect to size, weight, ovality, or the

# GENERAL TERMS AND CONDITIONS OF CONTRACT OF TIROLER GLASHÜTTE GMBH 2023 ("TG").

vertical axis according to the relevant technical drawings, which cannot be influenced by TG. Handmade Products or handmade Product parts may be subject to sample and size deviations. Therefore, all such deviations between Products, in particular compared to earlier deliveries of the same Product, do not constitute a defect.

**8.6.** In case of a valid claim in respect of any defective/non-compliant Product, TG will, at its sole discretion, either arrange delivery of a replacement Product (subject to its operational capabilities) or issue a credit note for the price paid by Customer to TG for the respective defective/non-compliant Product, but not both. If TG chooses to arrange delivery of a replacement Product, Customer is required to return the defective/non-compliant Product at Customer's cost and risk to the warehouse determined by TG. Any and all other warranty claims of Customer shall to the extent permitted by law be excluded. TG will not replace any Products broken or damaged if master packs are used for shipping (see **Clause 6.6.**). Further, damaged packaging is not replaceable.

**8.7.** The rights relating to defects and non-compliance do not apply in case a defect/non-compliance arises because Customer fails to observe TG's or a manufacturer's Product or Product packaging instructions, recommendations or guidelines, in particular instructions, recommendations and guidelines for processing, handling, use, caring or cleaning of the Product, or by failing to observe generally accepted Product use practices.

## 9. Limitations of Liability.

**9.1.** Where liability for damages is subject to fault, TG's liability for damages – irrespective of the legal grounds – shall in each case be limited in accordance with this **Clause 9.**

**9.2.** TG shall not be liable if and to the extent that Product instructions, recommendations and/or guidelines, in particular instructions for processing, handling, use, caring or cleaning of the Products and/or the Product packaging, and/or generally accepted Product use practices are not observed by Customer or its customer or other persons, unless Customer furnishes proof that the damage would have occurred even if the Product or Product packaging instructions, recommendations and/or guidelines had been observed. Further, TG shall not be liable for any damage or loss resulting from the purchase, handling, storage, packing, labelling, distribution, promotion, use, cleaning or sale of the Products by Customer.

**9.3.** TG shall only be liable for damage to the extent that the damage was caused by TG by gross negligence or willful intent. Liability for slight negligence is excluded, except in the case of personal injury. In such cases, however, TG's liability shall be limited to the foreseeable and typical damage.

**9.4.** The burden of proof lies with Customer.

**9.5.** In all other respects, TG's liability is excluded and Customer shall not be entitled to, and releases TG from, any additional claims, in particular for compensation of indirect damage or loss, or consequential damage, or loss of profits, goodwill revenue, savings or opportunity, whether in contract, tort (including negligence) or otherwise. For clarification, the cost of making a claim under this warranty will be borne by Customer.

**9.6.** Decorations of any kind not been made or commissioned by TG, such as engravings, silk-screenings etc., are the sole responsibility and risk of Customer. TG will not be responsible and shall be excluded from any warranty whatsoever, especially but not limited to that heavy metals or other dangerous materials are applied, or if the material used is not water-resistant or dishwasher-proof. Customer shall indemnify and hold TG and its affiliates harmless from any and all claims, suits, losses, damages, demands, injuries and expenses (including reasonable attorney's fees) arising out of or related to any claims made against TG based on any decorations (such as engraving, silk-screening, etc.) made to the Products by Customer.

**9.7.** Except as provided in the T&C, TG makes no warranties or representations as to the Products or services to Customer or to any other person. All implied warranties, including but not limited to implied warranties of merchantability and fitness for a particular purpose are hereby expressly excluded to the extent permitted by law.

## 10. Returns.

Unless due to their defectiveness or non-compliance Products are returned in accordance with **Clause 8.**, all returns are subject to TG's prior written approval and subject to the exclusions as set out in these T&C. Special Orders, Limited Editions, Products that were un-packed from the original boxes, 2 Glasses 1 Bottle Products, Products that have Authorized Packaging Changes or are engraved, decorated or are personalized in any other way cannot be returned and will not be reimbursed. Returned Products must be part of the current Price Books and in mint, resalable condition, packed in the original undamaged boxes and in the original sealed master packs. Returns must be shipped within thirty (30) days after having received TG's written prior approval and shall be delivered to the warehouse defined by TG, freight, risk and costs at Customer's expense and responsibility. For Products returned in accordance with these provisions and such Products not being defective/non-compliant under **Clause 8.**, the EXW TG warehouse, Germany, Product net price paid by the Customer for the respective purchase will be credited minus a 15% restocking and handling fee. Any returns not in conformity with the foregoing may be refused by TG and will be not reimbursed.

## 11. Intellectual Property Rights.

**11.1.** TG or TG's licensors hold any and all rights, titles, good-will, and interest of any nature whatsoever, including but not limited to any and all intellectual property rights,

in particular copyrights, trademarks, trade secrets, design patent, patent rights and/or design rights, relating to the Products, the Product designs, the glassware samples and the glassware sample designs and prototypes, including, but not limited to, the respective drawings, tools, shapes and molds.

**11.2.** Any and all tools, molds, drawings, plans and prototypes provided to a Customer are the sole property of TG, including but not limited to any and all intellectual property, even if Customer bears the costs of their acquisition in part or in full, and will not be handed over at the end of any kind of cooperation or contract.

**11.3.** Customer is entitled to the restricted use of the Brands and/or Trademarks affixed to the Products or their packaging in its unchanged and originally packed form, in order to identify the Products. By doing so, Customer does not acquire any rights or licenses to the Brands or the Trademarks, or any other proprietary material of TG or its licensors. Customer undertakes to refrain from any other use.

**11.4.** Any use of the Brands, the Trademarks or of any other intellectual property of TG or of TG's licensors, as well as photos or videos thereof, in publications, electronic (internet) advertising, social media pages, or printed matter is only permitted upon prior written authorization of TG. In addition, Customer undertakes not to use any marks or signs that are likely to be confused with those of TG or of TG's licensors, or with "Riedel", "Spiegelau" or "Nachtmann" or similar marks or signs or to have them protected in whatever form, in any jurisdiction.

**11.5.** Any and all materials and related documentation TG provides to Customer hereunder or through any contract together with any and all rights, titles and interests in the intellectual property, including but not limited to the Brands, the Trademarks, or any other proprietary material of TG and its licensors as well as all goodwill and copyright, in and arising from the Brands and the Products, vested therein or related thereto, remain the sole and exclusive property of TG or its licensors. Documents such as catalogues, brochures, illustrations, photos, videos, and the like as well as samples and designs remain at all times the intellectual property of TG or TG's licensors, protected by the relevant statutory provisions regarding reproduction, imitation, competition, etc. Customer undertakes not to make such material and documents available to third parties, either in whole or in part, without TG's prior written authorization or to use them for any purpose apart from the purpose for which they were handed over to Customer.

In case an authorization is granted that allows Customer to make such material and documents available to third parties, Customer shall be obliged to impose all obligations arising out of these T&Cs upon such third party. Customer remains liable to TG for any acts or omissions of such third party, and Customer shall hold TG and its affiliates harmless from any and all claims and expenses (including reasonable attorney's fees) arising out of or related to any such acts or omissions. If no Order is placed, Customer must return all material and documents.

**11.6.** Any use of the Brands or of any intellectual property rights of TG or of TG's licensors on social media platforms such as Facebook, Twitter, Instagram, TikTok etc. or any setting up of a "Riedel", "Spiegelau" or "Nachtmann" account on such social media platforms shall only be permitted upon prior written consent of TG.

## 12. Retention of Title.

**12.1.** TG shall retain title to the Products and samples delivered until full payment is received for such Products and/or samples by TG.

**12.2.** However, Customer is entitled to resell the Products in ordinary business in the usual way customary in the trade. If Products, which have not been paid for yet are sold, Customer shall assign the claim thus arising vis-à-vis third parties to TG. TG shall be entitled to disclose the assignment. Customer shall immediately make available to TG all information required in order to pursue all claims and agrees to comply with all formalities that may be necessary for a valid assignment.

**12.3.** Customer is not entitled to pledge or hand over Products of TG that have not been paid for as security. Customer is obliged to claim the title of TG to the Products in relation to third parties and to notify TG immediately in writing if third parties assert claims with respect to the Products or if execution is initiated.

## 13. Severability.

If any provision of the T&C is deemed ineffective or adjudicated to be invalid by a competent authority, the validity of the remaining provisions shall not be affected. The Parties shall agree on a new effective provision which comes as close as possible to the commercial purpose of the ineffective provision without delay.

## 14. Applicable Law, Place of jurisdiction.

**14.1.** The T&C and the contract concluded with Customer including the pre- and post-contractual phases and effects shall be governed by and shall be interpreted in accordance with **Austrian law**, excluding its conflict of law rules and the provisions of the UN Sales Law (CISG – United Nations Convention on Contracts for the International Sale of Goods).

**14.2.** The exclusive jurisdiction of Kufstein District Court, Austria, or Innsbruck High Court, Austria, (depending on jurisdiction over subject) is agreed for any and all disputes arising from or in relation to the contract concluded with Customer or the T&C underlying the contract, including the pre- and post-contractual phases and effects. However, TG is free to sue at Customer's registered office.

**AUSTRIA****Tiroler Glashütte GmbH**

Weissachstraße 28-34  
6330 Kufstein, Austria  
Phone: +43 (0) 5372 64896  
Fax: +43 (0) 5372 63225  
Email: info@riedel.com

**JAPAN****RSN Japan Co. Ltd**

Aoyama Twin Tower (West) 2 F  
1-1-1 Minami-Aoyama  
Minato-Ku, Tokyo 107-0062, Japan  
Phone: +81 3 4530 6900  
Fax: +81 3 5775 5889  
Email: info@riedel.co.jp  
www.riedel.co.jp

**AUSTRALIA****RSN Australia Pty Ltd**

201/32 Walker Street  
North Sydney NSW 2060, Australia  
Phone: +61 2 9966 0033  
Fax: +61 2 9906 7802  
Email: info@rsnaustralia.com.au

**NEW ZEALAND****RSN New Zealand Pty Limited**

PO Box 99841  
Newmarket 1149 Auckland, NZ  
Phone: +612 99 66 00 33  
Email: info@rsn.co.nz

**CANADA****Crystal of Canada, Inc.**

110 Fieldcrest Avenue  
Raritan Plaza 1, 4th Floor  
Edison, NJ 08837, USA  
Phone: +1 888 4-RIEDEL  
Fax: +1 732 346 8977  
Email: info@riedelcanada.com

**SWITZERLAND****RSN-Schweiz GmbH**

c/o KD Zug Fiduciary Ltd.  
Untermüli 7, Postfach 7444  
6302 Zug, Switzerland  
Phone: +41 41 766 26 35  
Email: webshopsui@riedel.com

**CHINA****RSN Crystal Trading (Shanghai) Ltd.**

RM2301-2302 Citic Plaza  
859 Sichuan Road North  
Shanghai 200085, China  
Phone: +86 21 60707358  
Email: info.asia@riedel.com

**UNITED KINGDOM****RSN.UK Ltd t/a Riedel**

Lakeside House  
3 Trentham Office Village  
Trentham Lakes South  
Stoke on Trent, ST4 8GH  
United Kingdom  
Phone: +44 (0) 1782 646 105  
Fax: + 44 (0) 1782 646 106  
Email: info@riedel.co.uk

**FRANCE****RSN Crystal France**

22 rue du Sentier  
75002 Paris  
Phone: +33 1 42 89 86 08  
Email: riedelfrance@riedel.com

**USA****Crystal of America, Inc.**

110 Fieldcrest Avenue  
Raritan Plaza 1, 4th Floor  
Edison, NJ 08837, USA  
Phone: +1 732 346 8960  
Fax: +1 732 346 8977  
Email: info@riedelusa.com

**GERMANY****RSN Deutschland GmbH Vertrieb**

Zacharias-Frank-Straße 7  
D-92660 Neustadt a.d. Waldnaab  
Phone: +49 (0) 9602 30-0  
Fax: +49 (0) 9602 30-1100  
Email: info@riedel.com

**RIEDEL.COM**